

Differential Magneto-resistive Sensor CY-DMR-01H

Features

- Sensing over wide rotation speed range
- Robust metallic or plastic housing
- Signal amplitude is speed independent
- Biasing magnet built in
- Best suited for harsh environments

Typical applications

- Speed detection
- Position detection
- Rotation detection
- Angle encoder
- Linear position sensing

The differential magneto-resistive sensor CY-DMR-01H consists of two series coupled magneto resistors (D-type InSb/NiSb semiconductor resistors whose value can be magnetically controlled), which are mounted onto an insulated ferrite substrate. The sensor is encapsulated in a metallic or plastic package and has 3 connection terminals. The basic resistance of the total system is $2 \times 600\Omega$. A permanent magnet, which supplies a biasing magnetic field, is fixed on the base of the sensor.

Case Style A: $\varnothing 8.5 \times 6.5 \text{mm}$

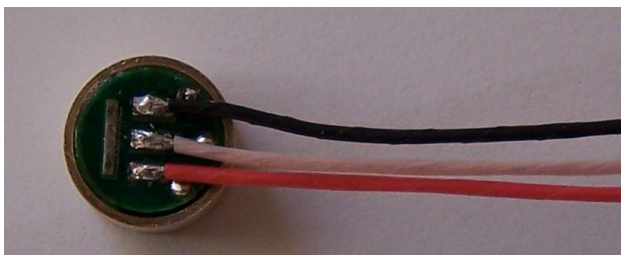
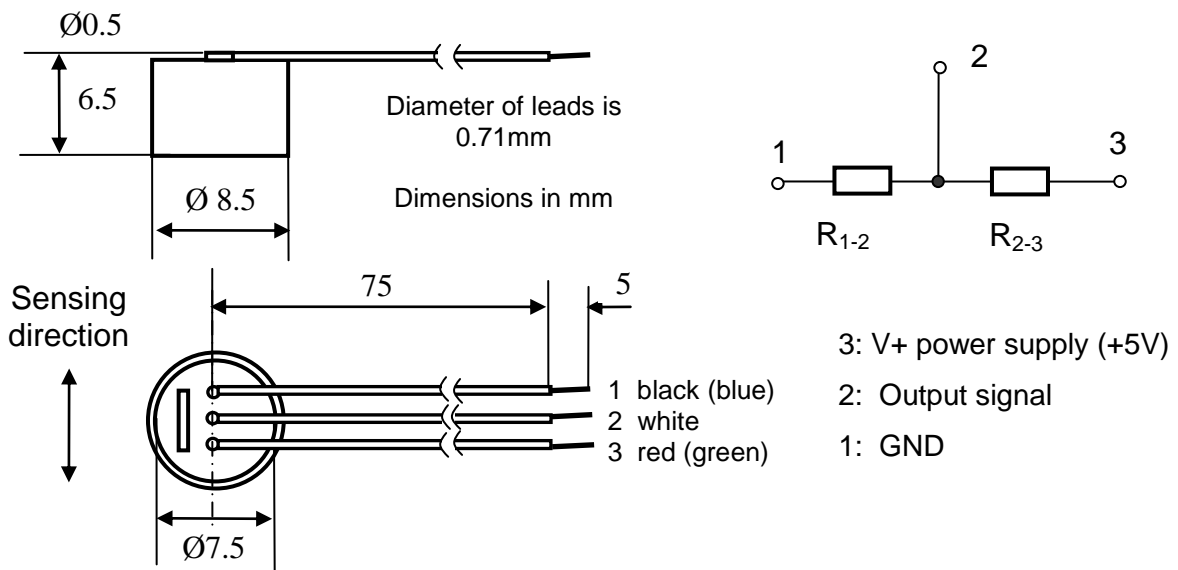

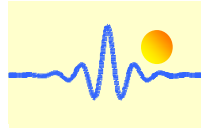

Case Style B: Ø10x10mm

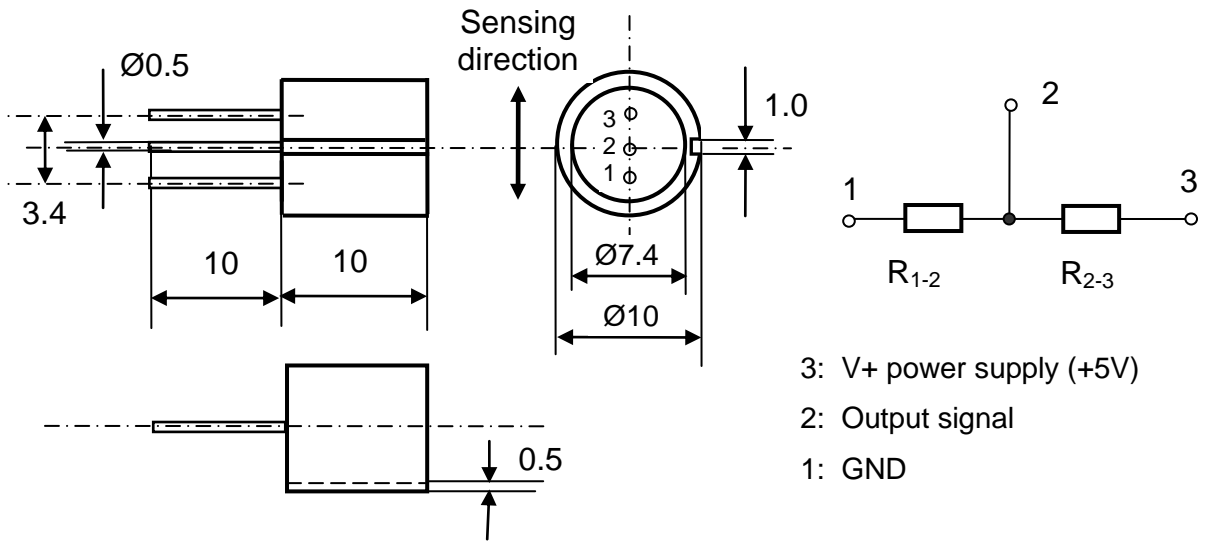

- 3: V+ power supply (+5V)
- 2: Output signal
- 1: GND

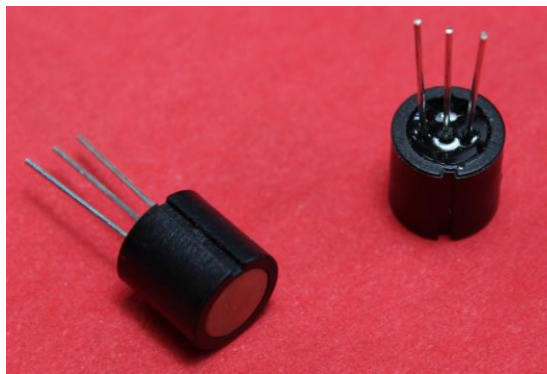

Specifications

Maximum power supply V_{max}	10V DC
Nominal power supply	5V DC
Total resistance R_{1-3} ($\delta=\infty$, $I \leq mA$, $t=25^\circ C$)	900 Ω – 1600 Ω
Center symmetry $M=100\%$ ($R_{1-2}-R_{2-3}$)/ R_{1-2} ($\delta=\infty$)	$\leq 10\%$
Offset voltage (at V_{in} and $\delta=\infty$)	$\leq 130mV$
Open circuit output voltage $V_{out pp}$ (at V_{in} and $\delta=0.15mm$)	$\geq 900mV$
Cut-off frequency	$> 20kHz$
Operating temperature	$-30^\circ C \sim +100^\circ C$
Storage temperature	$-40^\circ C \sim +100^\circ C$

Standard target object: 1.8x5x4mm (1.8x5mm face moves in the sensing direction of the sensor).

Part number

Part number	Case style	Outline	Cross reference
CY-DMR-01H-A	A	Ø8.5x6.5mm	Infineon FP212D250-22
CY-DMR-01H-B	B	Ø10x10mm	Infineon FP210D250-22

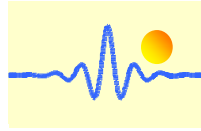

Measurement Arrangement

A measuring bridge is used for applications of the magnetoresistive sensor CY-DMR-01H. The resistances R_{2-3} and R_{1-2} of the sensor are changed by approaching a small soft iron part (standard target object) close to it. As result an output voltage change of measuring bridge is caused by the resistance change (see below).

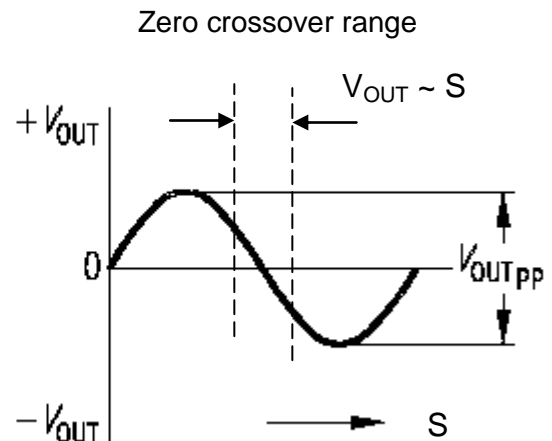
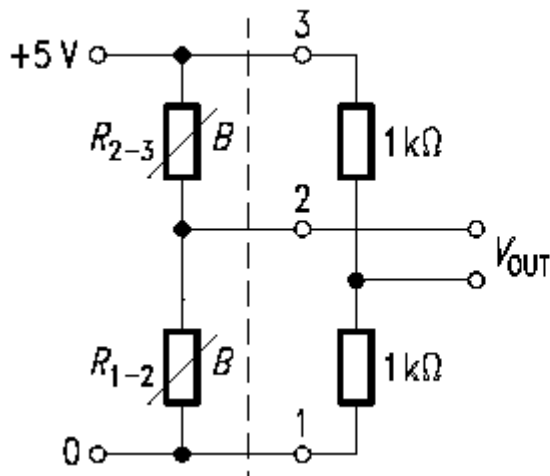
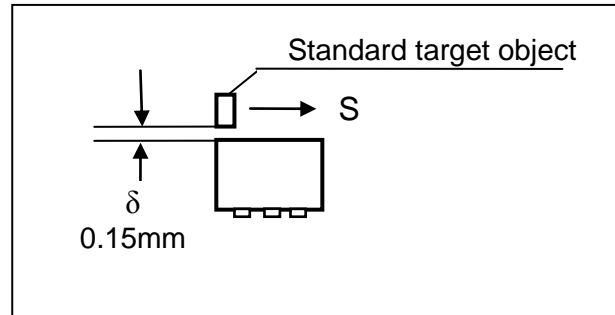

To convert small distance into a proportional electric signal, one can use a small soft iron part with definite width (e.g. $b=1.8\text{mm}$) to move over the face of the sensor. A linear signal up to 1.5mm can be obtained in this way. The sinusoidal signal gives a voltage output proportional to the distance in the zero crossover range.