

Single-phase AC Voltage Transducer CYVJ03

The **CYVJ03 Series**, Loop-Powered AC Voltage Sensors/Transducers are designed for applications to measurement and monitoring of single phase AC voltages. The output signals (DC voltage and current) of these transducers are proportional to the average effective value (RMS) of input AC voltages. They are suitable for general applications such as fixed frequency voltage supplies.

Specifications

Series	Operating Principle	Isolation Voltage	Response Time Range 0 to 90% FS	Overload Capacity	Quiescent Power consumption (mW)		Mounting
					Vz, Vd, Vg, Iz Output	Iy Output	
CYVJ03	Electromagnetic Induction	≤2500V DC	≤400mS	2 Times 10/sec	50(H) 180(S)	250	Surface or Din rail

Part Numbers

Series	Output	Power Source	Window Opening(mm)	Case Style	Accuracy	Rated Input (RMS)
CYVJ03	3: 0~5V DC (Vz) 8: 0~10V DC (Vd)	2: 12V 3: 15V	M: None	H1	0.5%	100V, 110V, 220V, 250V, 380V, 400V, 500V, 1000V
	1: 0~5V RMS(Vg) 3: 0~5V DC (Vz) 4: 0~20mA (Iz)* 5: 4~20mA (Iy)* 8: 0~10V DC (Vd)	2: 12V 3: 15V 4: 24V		S2 S3	0.5%	

* Loop resistance from 0 to 250Ω. Contact factory for loop resistance above 250 Ω

Code	Symbol	Definition	Applications
1	Vg	Tracing Voltage Output	0-5V (RMS or V_{p-p}), suitable for AC or peak value sampling system, quick response, high precision.
3	Vz	DC Voltage Output	0-5 V DC, can be connected direct to A/D converter, digit panel, indicator, PLC
4	Iz	DC Current Output	0-20 mA DC, suitable for long distance signal transmission, resistance to interference.
5	Iy	DC Current Output	4-20 mA DC, suitable for long distance signal transmission, resistance to interference.
8	Vd	DC Voltage Output	0-10 V DC, can be connected direct to digit panel, indicator etc. (power source ≥15V).

Application of CYVJ03:

- Monitor for over/under voltage
- Power monitoring
- Multi-point instrumentation needs
- Sense phase loss

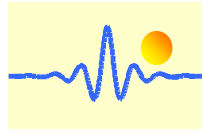

Case Style

Case Style H1

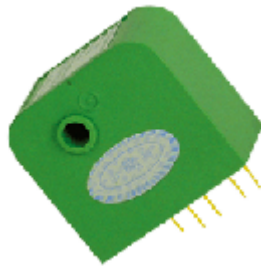

Installation

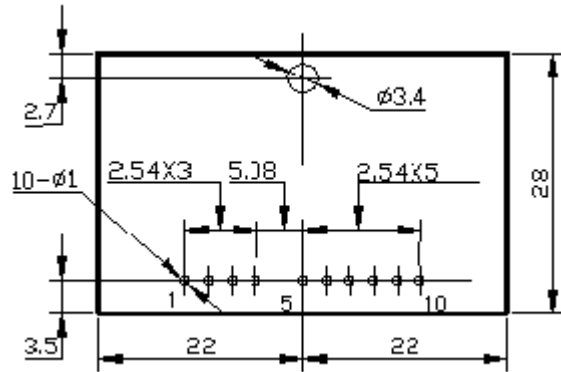

Case Style S2 without Aperture



Installation

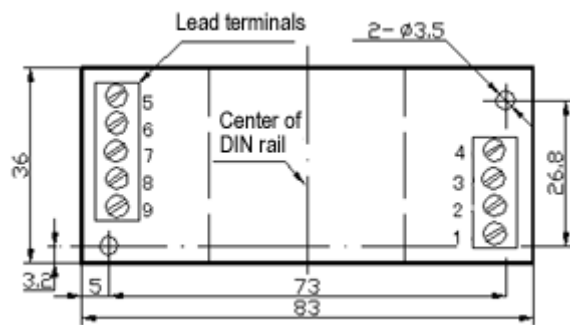

Case Style S3 without Aperture



Installation

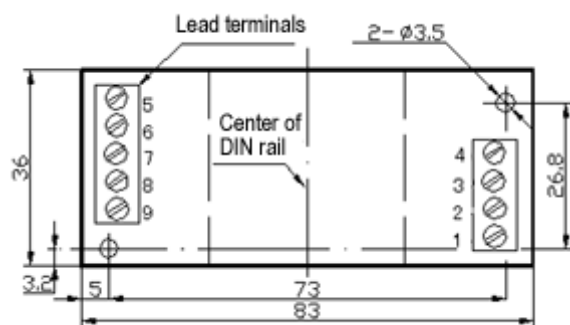
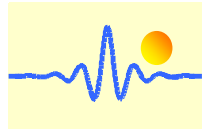

Fig. 1 Case Styles for CYVJ03



Connection

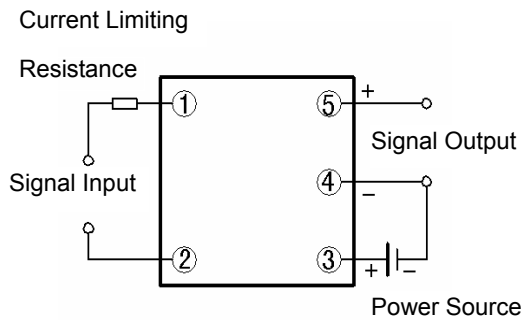

Fig. 2 Case Style H1 for CYVJ03

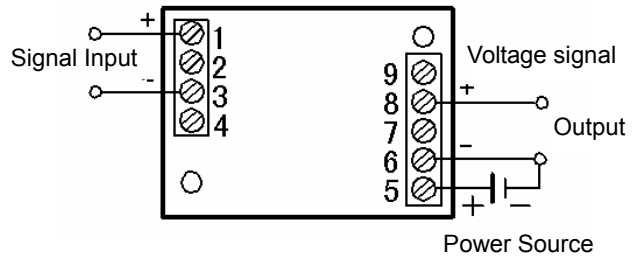

Fig. 3 Case Style S for voltage output of CYVJ03

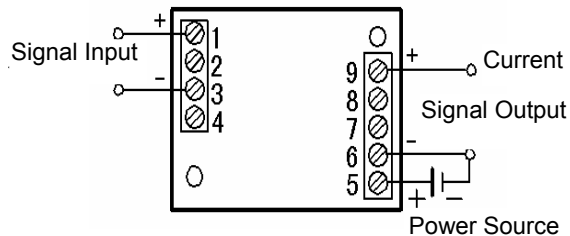

Fig.4 Case Style S for CYVJ03 Current Output

Notice:

1. Selection of output signal: Please select power source >12V at 0~10V output.
2. The H1 type must be used with corresponding current limiting resistance. The current limiting resistance should not be out near by the output terminal (larger voltage drop)
3. The output signal and the power source must be earthed in common. Please keep right connection, don't in error set.