

CYCT-T24 Split Core Current Transformer

CYCT-T24 Split Core Current Transformer is an instrument transformer, which is used along with measuring or protective devices, in which the secondary current is proportional to the primary current (under normal conditions of operation) and differs from the primary current by a phase drift that is approximately zero.

Specifications

Operating temperature	-40°C ~ 85°C
Primary Current 50/60Hz	0~200A (10A, 50A, 100A, 200A, 300A)
Output signal	0~66.6mA AC (optional 0~5A/0~10V AC, 0-5VDC, 4-20mADC, 0-5VDC, 0-10VDC)
Accuracy @ $RL \leq 10\Omega$	$\pm 0.5\%$ for AC output, $\pm 1.0\% \sim \pm 2.0\%$ for DC output
Linearity @ $RL \leq 10\Omega$	$\pm 0.2\%$ for AC output, $\pm 0.5\% \sim \pm 1.0\%$ for DC output
Turns ratio (1:N)	1:100 ~ 1:8000 optional
Phase error at rated current range	2 degree
Dielectric Withstanding Voltage (Hi-pot)	4kV RMS/1mA/1min
Impulse Withstand Voltage	5kV peak
Insulation Resistance	$\geq 100M\Omega$
Inflaming retarding of case	UL94-V0
Certificate	CE, UL, ET
Opening Angle	180°

Dimensions (mm)

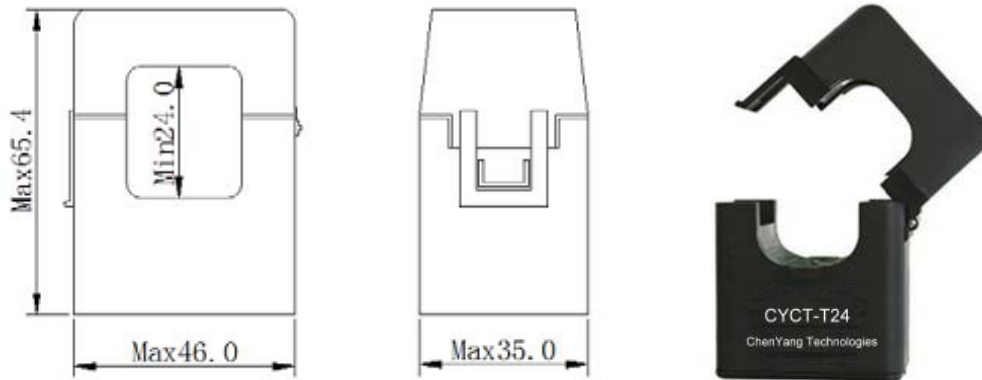

Test Circuit

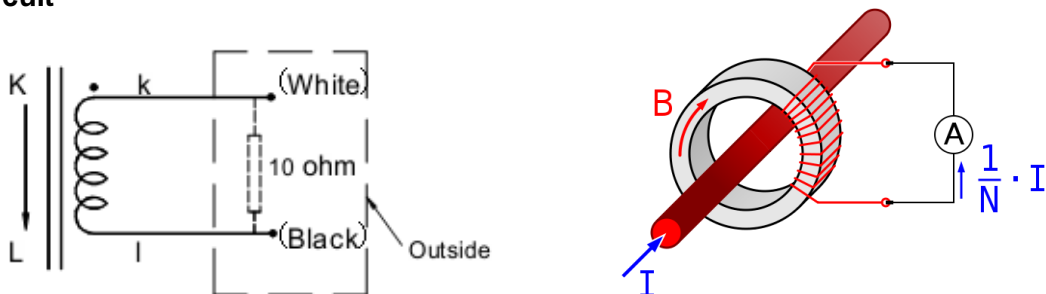

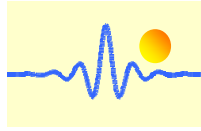

Principle

The basic principle of the current transformer is the same as that of the power transformer. Like the power transformer, the current transformer also contains a primary conductor and a secondary winding. Whenever an alternating current flows through the primary conductor, alternating magnetic flux is produced, which then induces alternating current in the secondary winding. In the case of current transformers, the load impedance is very small. Therefore the current transformer operates under short circuit conditions. Also the current in the secondary winding does not depend on load impedance but instead depends on the current flowing in the primary conductor.

The current transformer basically consists of an iron core upon which the secondary winding is wound. The primary conductor is passed through the hole of the current conductor, while the secondary winding is connected to a measuring device or a relay. The secondary current is inversely proportional to the current flowing in the primary conductor I_p , i.e. $I_s = I_p / N$ with N as the number of secondary winding.

Characteristic Curves

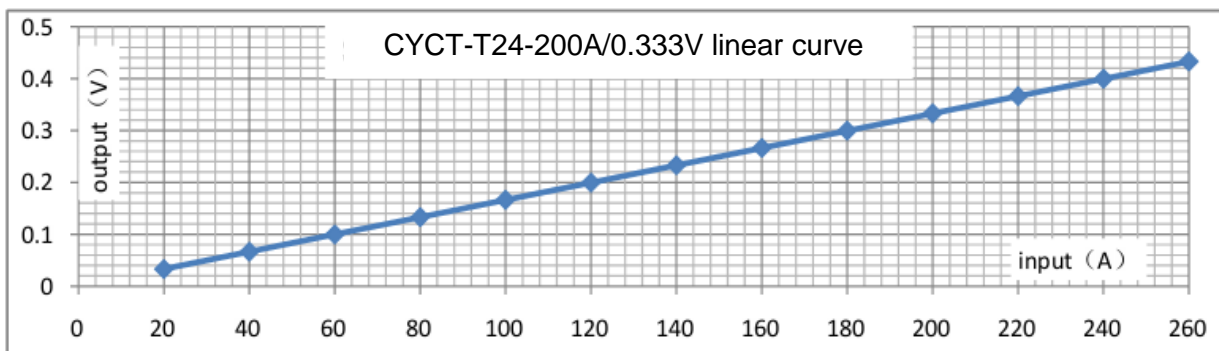
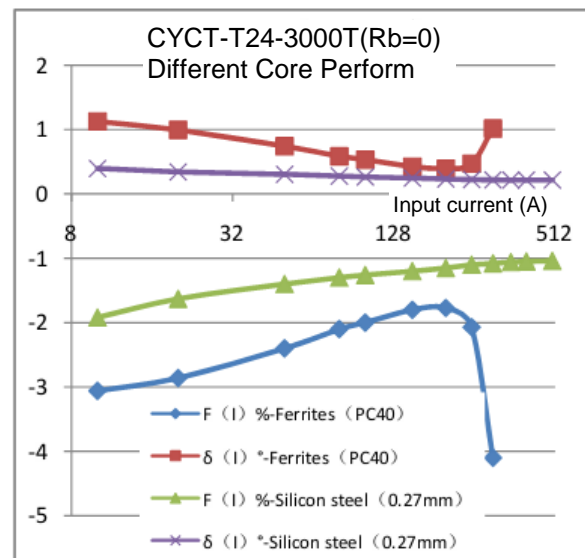
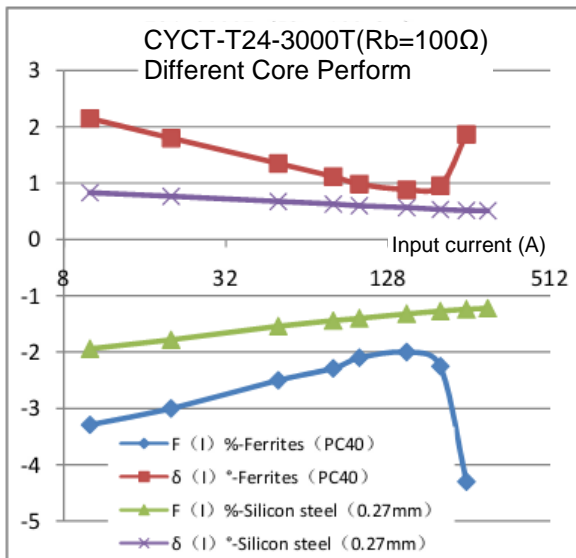

Applications:

- Measuring Instruments (ammeters, watt-meters, energy-meters)
- Protective relays
- AC current conversion
- AC current Measurement etc.