



## DC Current Sensor CYCT01-xnS1

The **CYCT01-xnS1** DC current sensor/transducer works according Photoelectrical Induction and is designed for applications to measurement and monitoring of DC current. The output signal (DC voltage or current) of this transducer is proportional to the input DC current. They are suitable for measurements and long time monitoring of DC currents and can applied to power supply management, DC motor drivers, battery chargers and systems etc.

### Specifications

Rated input current range	20mA, 50mA, 100mA, 200mA
Output signal	0-5VDC, 0-20 mA, 4-20 mA, 0-10V DC, frequency OC
Power supply	+12V, +15V, +24V DC
Measuring accuracy	0.5%
Isolation (three-isolation)	between input, output and power supply
Load resistance	≥2kΩ for voltage output, ≤250Ω for current output
Isolation withstanding voltage	2.5 kV DC, 1min, leakage current 1mA
Operating temperature	-10°C ~ +60°C
Storage temperature	-25°C ~ + 70°C
Relative humidity	10% ~ 90%
Response time	≤10ms
Overload capacity	2 times
Quiescent power consumption	180mW – 300mW
Mounting	Din rail
Case style	S1 without aperture

### Definition of Part number:

CYCT01	-	x	n	S1	-	0.5	-	M
(1)		(2)	(3)	(4)		(5)		(6)

(1)	(2)	(3)	(4)	(5)	(6)
Series name	Output signal	Power supply	Case style	Accuracy class	Input current range (M=U/B+m)
CYCT01	<b>x=3:</b> 0-5V DC <b>x=4:</b> 0-20mA DC <b>x=5:</b> 4-20mA DC <b>x=8:</b> 0-10V DC <b>x=F:</b> Frequency OC**	<b>n=2:</b> +12V DC <b>n=3:</b> +15V DC <b>n=4:</b> +24V DC	S1	0.5%	m= 20mA, 50mA, 100mA, 200mA

\*\* Frequency range: 10kHz, accuracy: 0.5%, response time is longer than those given in the table above  
**U:** unipolar input current;      **B:** bipolar input current

### Output Signal of Custom Made Sensors:

**x=1:** tracing voltage 5V, **x=2:** tracing current 20mA

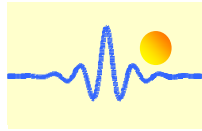

**Example 1:** CYCT01-32S1-0.5-U100mA, DC Current sensor with  
Output signal: 0-5V DC  
Power supply: +12V DC  
Rated input current: 0-100mA DC (unipolar)

**Example 2:** CYCT01-54S1-0.5-B100mA, DC Current sensor with  
Output signal: 4-20mA DC  
Power supply: +12V DC  
Rated input current: -100mA ~ +100mA DC (bipolar)

**DIMENSIONS (mm)**

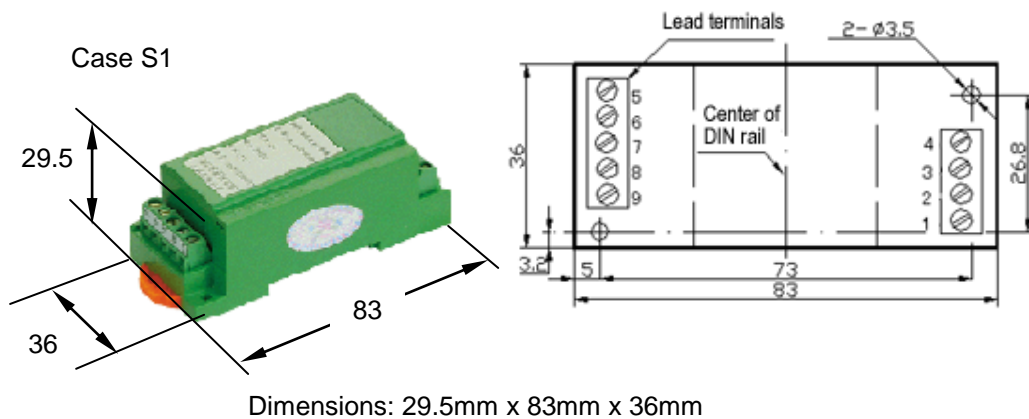

**CONNECTIONS**

**Wiring of Terminals for voltage output:**

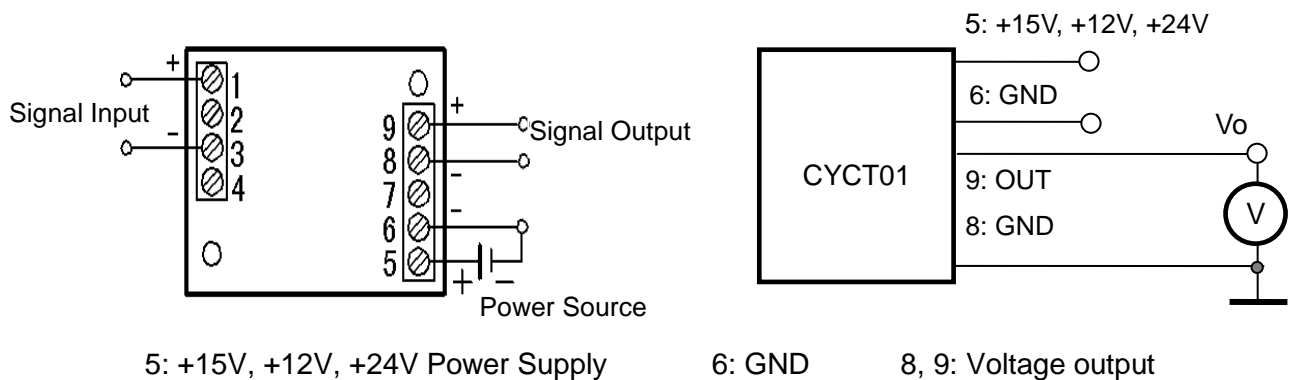

**Relation between Input and Output:**

Sensor CYCT01-32S1-0.5-U100mA		Sensor CYCT01-32S1-0.5-B100mA	
Input current (mA)	Output voltage (V)	Input current (mA)	Output voltage (V)
0	0	-100	0
25	1.25	-50	1.25
50	2.5	0	2.5
75	3.75	50	3.75
100	5	100	5



### Wiring of Terminals for Current Output:

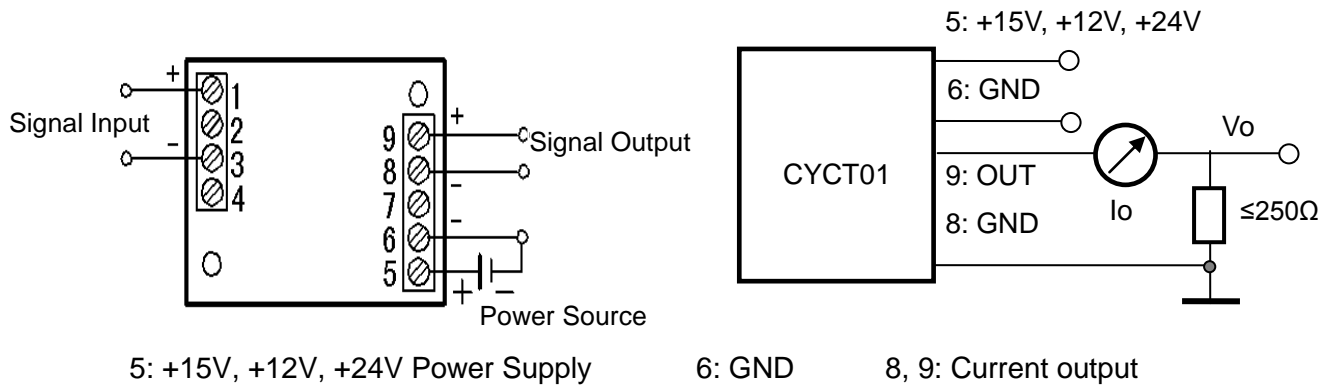

Relation between Input and Output (for  $R_m=250 \Omega$ ):

Sensor CYCT01-54S1-0.5-U100mA			Sensor CYCT01-54S1-0.5-B100mA		
Input current (mA)	Output current $I_o$ (mA)	Output voltage $V_o$ (V)	Input current (mA)	Output current $I_o$ (mA)	Output voltage $V_o$ (V)
0	4	1	-100	4	1
25	8	2	-50	8	2
50	12	3	0	12	3
75	16	4	50	16	4
100	20	5	100	20	5

### Wiring of Terminals for OC Frequency Output:

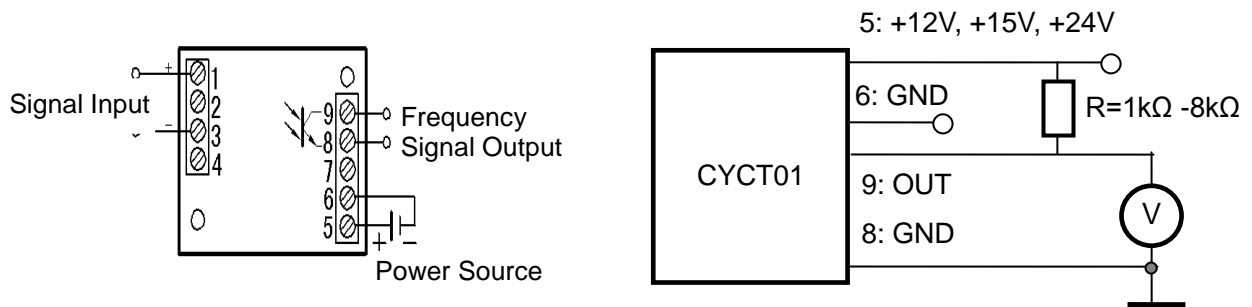

The value of the pull-up resistor R should be selected in order to get a current of 4-5mA flowing through the pull-up resistor. For instance the pull-up resistor is  $24V/4.5mA=5.3k\Omega$  if you use a power supply +24VDC.

Recommended value of the pull-up resistor R

Power supply	+12V	+15V	+24V
Pull-up resistor R	2.6kΩ	3.3kΩ	5.3kΩ