

DC Current Sensor CYCT02-xnS2

The **CYCT02-xnS2** DC current sensor/transducer works according Magnetic Modulation and is designed for applications to measurement and monitoring of DC current. The output signal (DC voltage or current) of this transducer is proportional to the input DC current. They are suitable for measurements and long time monitoring of DC currents and can applied to power supply management, DC motor drivers, battery chargers and systems etc.

Specifications

Rated input current range	500mA, 1A, 2A, 5A
Output signal	0-5VDC, 0-20 mA, 4-20 mA, 0-10V DC, frequency OC
Power supply	+12V, +15V, +24V DC
Measuring accuracy	0.5%
Isolation	between input, output and power supply
Load resistance	≥2kΩ for voltage output, ≤250Ω for current output
Isolation withstanding voltage	2.5 kV DC, 1min, leakage current 1mA
Operating temperature	-10°C ~ +60°C
Storage temperature	-25°C ~ + 70°C
Relative humidity	10% ~ 90%
Response time	≤15ms
Overload capacity	2 times
Quiescent power consumption	200mW – 300mW
Mounting	Din rail
Case style	S2 without aperture

Definition of Part number:

CYCT02	-	x	n	S2	-	0.5	-	M
(1)		(2)	(3)	(4)		(5)		(6)

(1)	(2)	(3)	(4)	(5)	(6)
Series name	Output signal	Power supply	Case style	Accuracy class	Input current range (M=U/B+m)
CYCT02	x=3: 0-5V DC x=4: 0-20mA DC x=5: 4-20mA DC x=8: 0-10V DC x=F: Frequency OC**	n=2: +12V DC n=3: +15V DC n=4: +24V DC	S2	0.5%	m= 500mA, 1A, 2A, 5A

** Frequency range: 10kHz, accuracy: 0.5%, response time is longer than those given in the table above
U: uni-directional input current; **B:** bi-directional input current

Output Signal of Custom Made Sensors:

x=1: tracing voltage 5V, **x=2:** tracing current 20mA

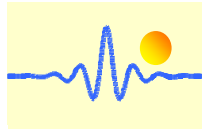

Example 1: CYCT02-32S2-0.5-U2A, DC Current sensor with
Output signal: 0-5V DC
Power supply: +12V DC
Rated input current: 0-2A DC (uni-directional)

Example 2: CYCT02-54S2-0.5-B2A, DC Current sensor with
Output signal: 4-20mA DC
Power supply: +12V DC
Rated input current: -2A ~ +2A DC (bi-directional)

DIMENSIONS (mm)

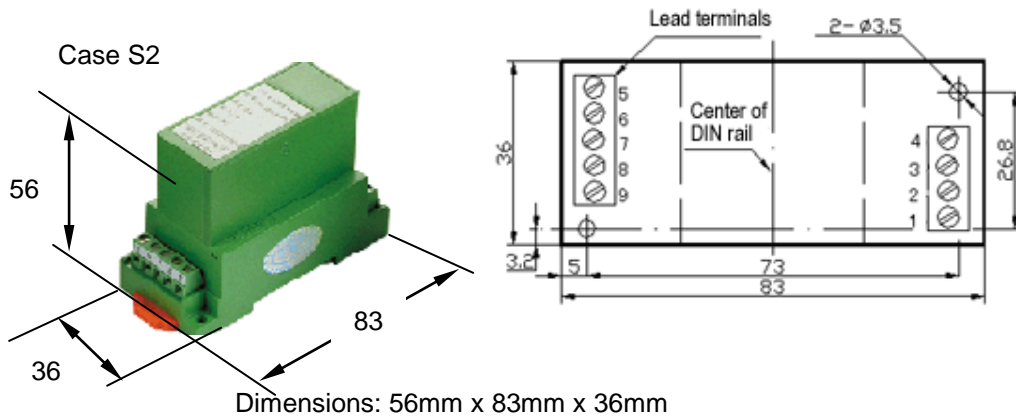

CONNECTIONS

Wiring of Terminals for voltage output:

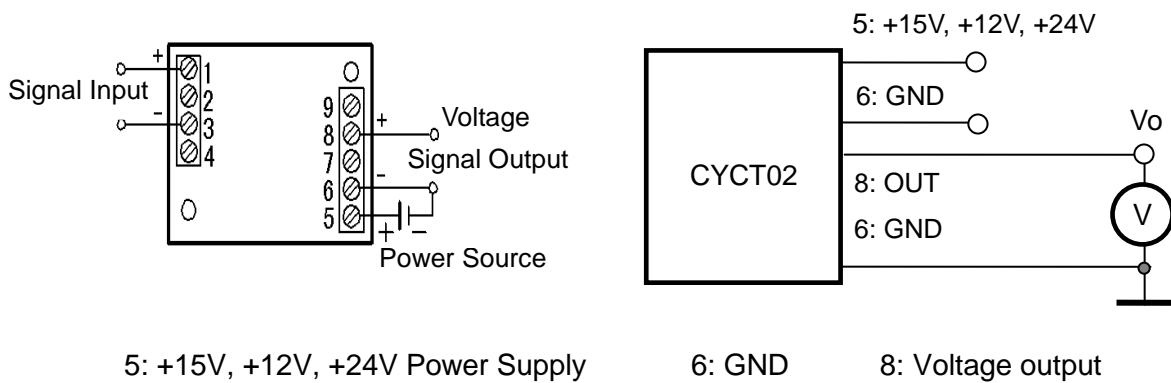

Relation between Input and Output:

Sensor CYCT02-32S2-0.5-U2A		Sensor CYCT02-32S2-0.5-B2A	
Input current (A)	Output voltage (V)	Input current (A)	Output voltage (V)
0	0	-2	0
0.5	1.25	-1	1.25
1	2.5	0	2.5
1.5	3.75	1	3.75
2	5	2	5

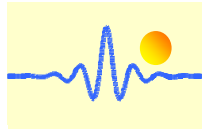

Wiring of Terminals for Current Output:

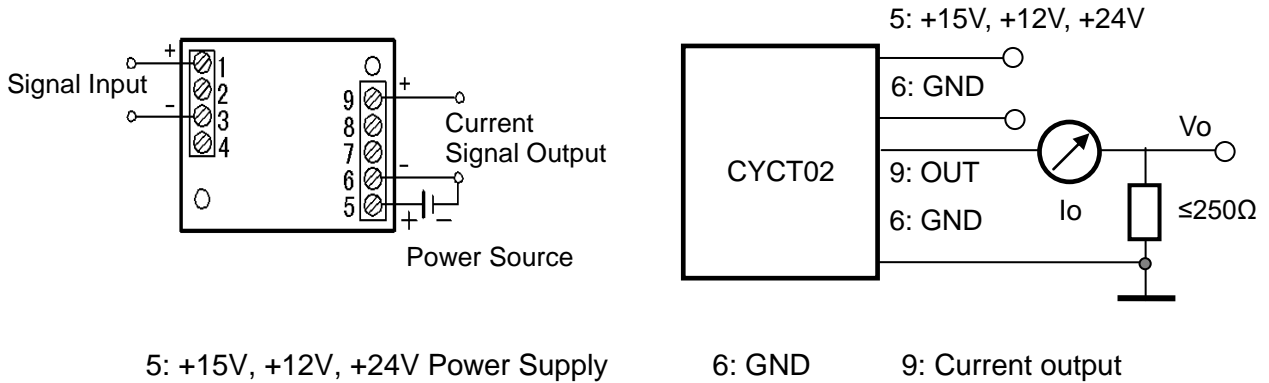

Relation between Input and Output (for $R_m=250\ \Omega$):

Sensor CYCT02-54S2-0.5-U2A			Sensor CYCT02-54S2-0.5-B2A		
Input current (A)	Output current I_o (mA)	Output voltage V_o (V)	Input current (A)	Output current I_o (mA)	Output voltage V_o (V)
0	4	1	-2	4	1
0.5	8	2	-1	8	2
1	12	3	0	12	3
1.5	16	4	1	16	4
2	20	5	2	20	5

Wiring of Terminals for OC Frequency Output:

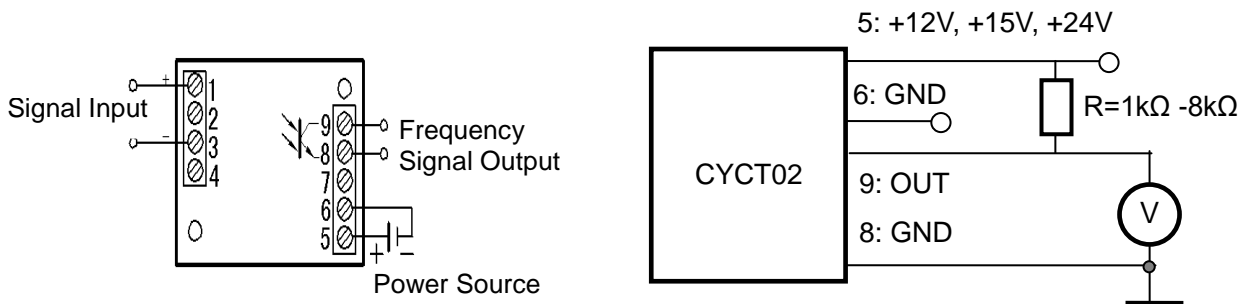

The value of the pull-up resistor R should be selected in order to get a current of 4-5mA flowing through the pull-up resistor. For instance the pull-up resistor is $24V/4.5mA=5.3k\Omega$ if you use a power supply +24VDC.

Recommended value of the pull-up resistor R

Power supply	+12V	+15V	+24V
Pull-up resistor R	2.6k Ω	3.3k Ω	5.3k Ω

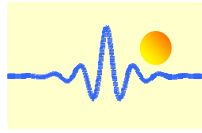

Applications:

- Power supply management
- DC motor drives
- Battery chargers and systems
- Mobile applications.

Notice:

- If the input signal is bi-directional DC or pulse DC, please give a remark in your order.
- The output and the power supply must be common grounded at terminal 6.
- If the input current is higher than 1A, it is necessary to connect terminals 1&2 and terminals 3&4 in parallel in order to reduce the input resistance at the input terminals.