

DC Current Sensor CYCT04-xnM20A

This current sensor is based on magnetic modulation and compensation principle, and can be used for measurement of small DC current and leakage current, current difference between two or more conductors.

Product Characteristics:

- Application of Computer Aided Ageing Technology
- 100% Ageing Processing and Thermal Drift Test under high operating temperature in order to guarantee the long term stability of the sensors
- Custom makeable according to individual requirements
- Various current and voltage outputs are selectable
- Power supply options: $\pm 12\text{VDC}$ and $\pm 15\text{VDC}$, single power supply is possible.
- Sensors with window for contactless measurements

Applications:

- Isolation Monitoring of DC power systems and cable selection systems,
- Measurements of small DC currents and leakage currents etc.

Electrical Data

Measuring range M	10mA ~ 2A DC
Linearity range	1.2 x M (measuring range)
Nominal output signals	0-5V, -5V~+5V, 4-20mA, 0-20mA, -20mA~+20mA
Supply voltage	$\pm 12\text{VDC}$, $\pm 15\text{VDC}$
Current consumption	12mA + output current
Galvanic isolation	2KV RMS/50Hz/min
Measuring resistance for current output	$\leq 250\Omega$

Accuracy and Dynamic Performances

Thermal drift of offset current	Typ. 100; max. 250	ppm/°C
Response time	≤ 120	ms
Accuracy	± 1.0	%
Linearity	≤ 1.0	%FS

General Data

Operating temperature	-10 ~ +70	°C
Storage temperature	-40 ~ +70	°C
Window size	$\Phi 20$	mm
Case dimensions H x L x W	73 x 87.5 x 25	mm

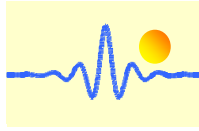

Definition of Part number:

CYCT04	-	x	n	M20A	-	1.0	-	M
(1)	(2)	(3)	(4)	(5)	(6)	(7)	(8)	(9)

(1)	(2)	(3)	(4)	(5)	(6)
Series name	Output signal	Power supply	Case style	Accuracy	Rated Input current (M=U/B + m)
CYCT04	x=1: tracing $\pm 5VDC$ x=2: tracing $\pm 20mA$ DC x=3: 0-5V DC x=4: 0-20mA DC x=5: 4-20mA DC	n=5: $\pm 12V$ DC n=6: $\pm 15V$ DC	M20A With aperture $\varnothing 20mm$	1.0%	$m = 10mA, 20mA, 50mA, 100mA, 200mA, 500mA, 1A, 2A$

U: unidirectional input current; **B:** bidirectional input current

Example 1: CYCT04-56M20A-1.0-U10mA, DC Current sensor with
Output signal: 4-20mA DC
Power supply: $\pm 15V$ DC
Rated input current: 0-10mA DC (unidirectional)

Example 2: CYCT04-15M20A-1.0-B10mA, DC Current sensor with
Output signal: $\pm 5V$ DC
Power supply: $\pm 12V$ DC
Rated input current: -10mA ~ +10mA DC (bidirectional)

DIMENSIONS (mm)

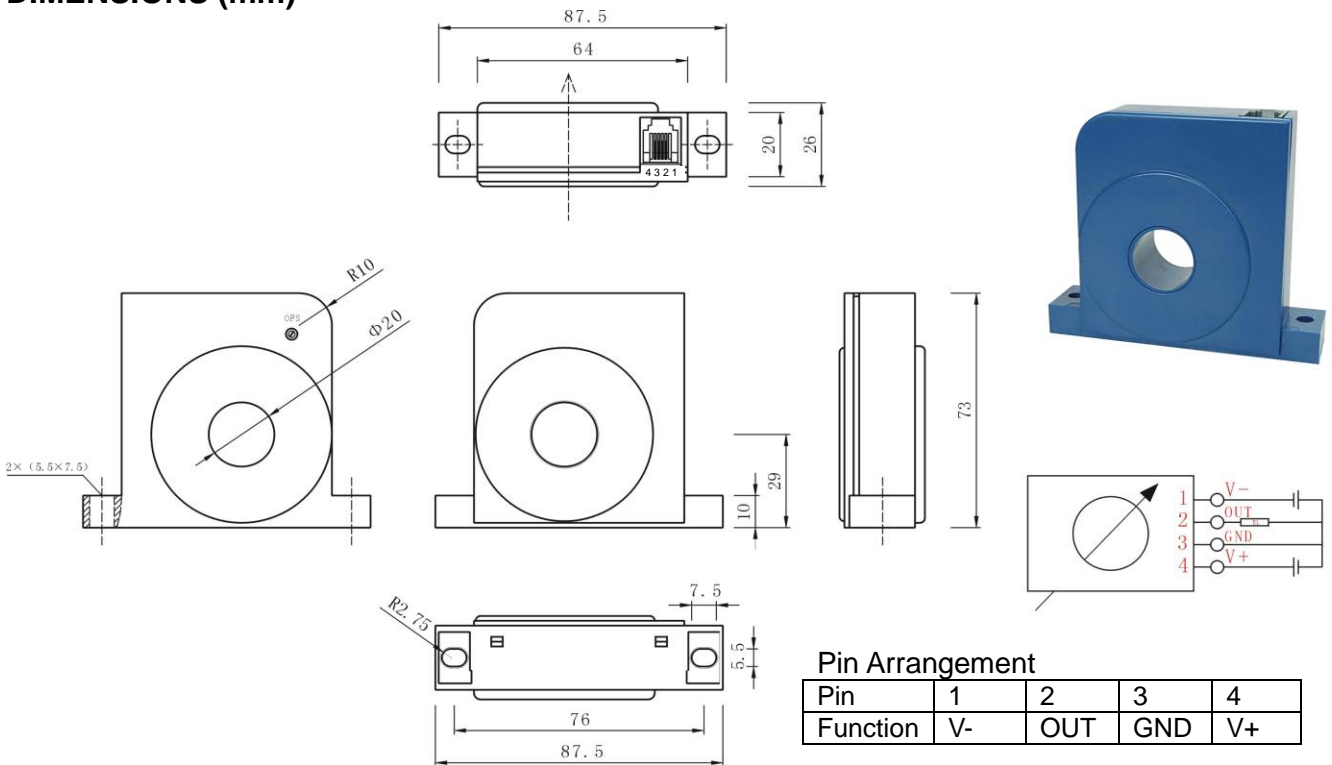

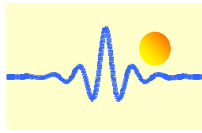

CONNECTION

The current carrying cable must pass through the window. The phase of output is the same as that of the current passing the window in the direction of the arrow indicated on the case.

a) Voltage Output

- 1: V- Power Supply
- 2: Output
- 3: Ground
- 4: V+ Power Supply

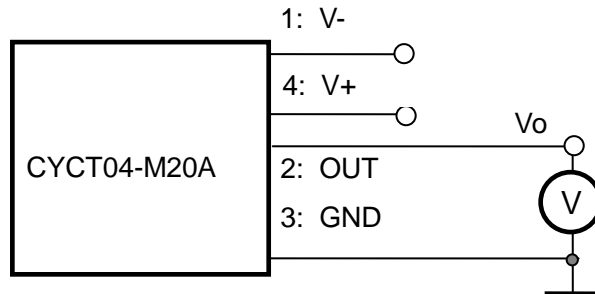

Relation between Input and Output:

Sensor CYCT04-35M20A-1.0-U10mA		Sensor CYCT04-15M20A-1.0-B10mA	
Input current (mA)	Output voltage (V)	Input current (mA)	Output voltage (V)
0	0	-10	-5
2.5	1.25	-5	-2.5
5	2.5	0	0
7.5	3.75	5	2.5
10	5	10	5

b) Current Output

- 1: V- Power Supply
- 2: Output
- 3: Ground
- 4: V+ Power Supply

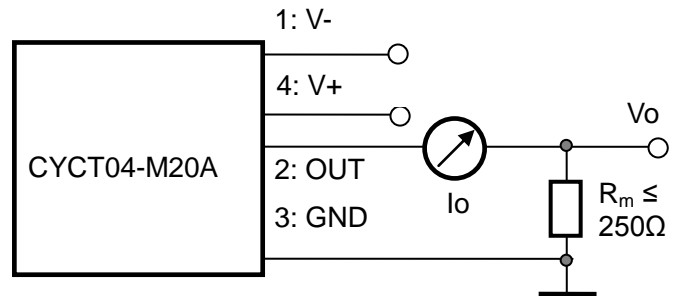

Relation between Input and Output (for $R_m=250 \Omega$):

Sensor CYCT04-56M20A-1.0-U10mA			Sensor CYCT04-25M20A-1.0-B10mA		
Input current (mA)	Output current I_o (mA)	Output voltage V_o (V)	Input current (mA)	Output current I_o (mA)	Output voltage V_o (V)
0	4	1	-10	-20	-5
2.5	8	2	-5	-10	-2.5
5	12	3	0	0	0
7.5	16	4	5	10	2.5
10	20	5	10	20	5

Notes:

1. Connect the terminals of power source, outputs respectively and correctly, never make wrong connection.
2. The potentiometer can be adjusted, only if necessary, by turning slowly to the required accuracy with a small screwdriver.
3. The best accuracy can be achieved when the window is fully filled with current carrying conductor
4. The in-phase output can be obtained when the direction of current of current carrying conductor is the same as the direction of arrow marked on the transducer case.