

CYD3141E SERIES HALL-EFFECT SWITCH IC

CYD3141E series Hall-effect switch integrated circuits for high temperature operating based on Hall-effect principle, apply the semiconductor monolithic technology, which includes a voltage regulator, Hall voltage generator, differential amplifier, Schmitt trigger and an open-collector output on a single silicon chip. ICs can convert the input magnetic field signal into digital voltage output.

FEATURES

- ◆ Small size
- ◆ High Sensitivity
- ◆ Quick Response
- ◆ Good Temperature Performance
- ◆ High Accuracy
- ◆ Excellent Reliability

TYPICAL APPLICATION

- ◆ Non-contact Switch
- ◆ Automotive Ignition
- ◆ Brake ICs
- ◆ Position control
- ◆ Revolution detection
- ◆ Safe alarm device
- ◆ Textile control system

FUNCTIONAL BLOCK DIAGRAM

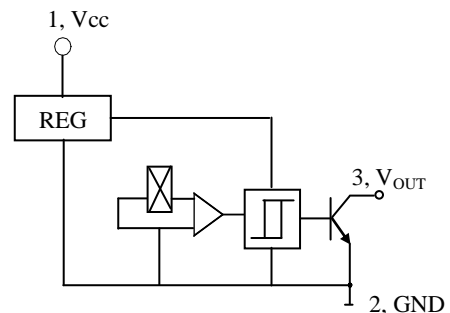

ABSOLUTE MAXIMUM RATINGS

Parameter	Symbol	Value	Unit
Supply Voltage	V _{CC}	28	V
Quiescent Output Voltage	V _O	28	V
Output Current	I _O	25	mA
Operating Temperature Range	T _A	-40~85	°C
Storage Temperature Range	T _S	-65~150	°C

Magnetic-Electrical Transfer Characteristics

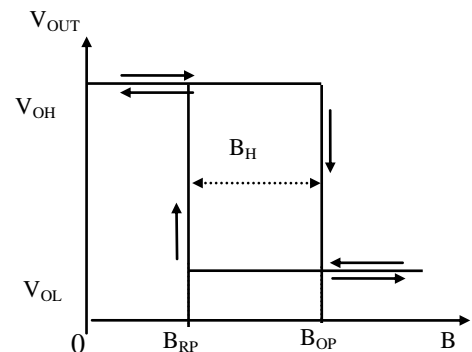

ELECTRICAL CHARACTERISTICS

Parameter	Test Condition	Symbol	Value			Unit
			Min	Typ	Max	
Supply Voltage	V _{CC} =4.5V~24V	V _{CC}	4.5	-	24	V
Output Low Voltage	V _{CC} =4.5v, V _O =24V I _O =20mA, B≥B _{OP}	V _{OL}	-	175	400	mV
Output Leakage Current	V _O =24V, B<B _{RP}	I _{OH}	-	<1.0	10	μA
Supply Current	V _{CC} =24V, V _O open-collector output	I _{CC}	-	3.0	9.0	mA
Output Rise time	V _{CC} =12V, R _L =820Ω C _L =20pF	tr	-	0.2	2.0	μS
Output Fall time		tf	-	0.18	2.0	μS

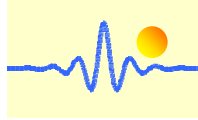

Magnetic Characteristics

Parameter		Min (mT)	Typ (mT)	Max (mT)
Operate Point (B_{OP})	$T_A=25^\circ\text{C}$	5.0	10.0	16.0
	Full Operating Temperature Range	3.0	10.0	17.5
Release Point (B_{RP})	$T_A=25^\circ\text{C}$	1.0	4.5	13.0
	Full Operating Temperature Range	1.0	4.5	14.5
Hysteresis (B_H)	$T_A=25^\circ\text{C}$	2.0	5.5	8.0
	Full Operating Temperature Range	2.0	5.5	8.0

Package Outline Drawing (Unit: mm)

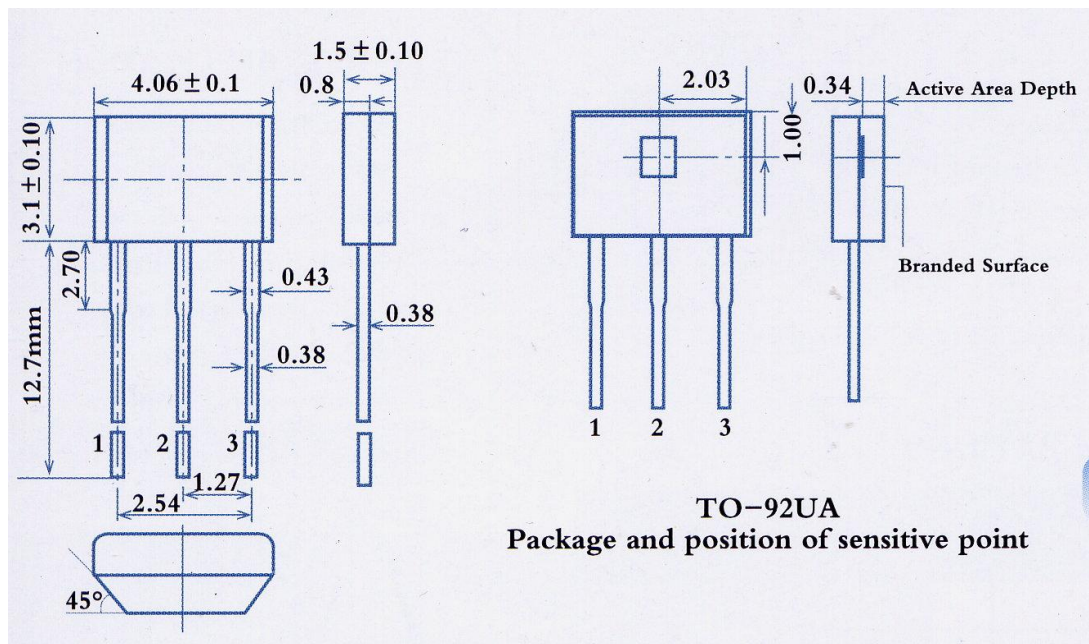

Pin Notes: 1. Power Supply, 2. Ground, 3. Output

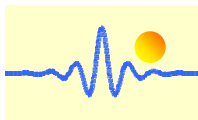

Connection

This sensor has an OC (NPN) output voltage. Therefore it is necessary to connect a pull-up resistor in value from $1\text{k}\Omega$ to $10\text{k}\Omega$ between the power supply V_{cc} and output pins.

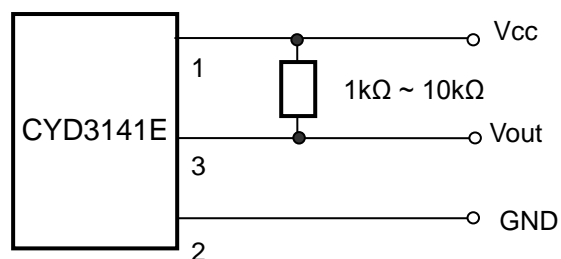

Cautions:

- 1) It is possible that outside mechanical stress affects the operating point and the release point of Hall-effect circuit, therefore, mechanical stress should be lessened as far as possible in the process of assembly;
- 2) Pay attention to the soldering temperature at the leads; keep it lower in a short time to guarantee good soldering quality.