

Hall Effect DC/AC Current Sensor CYHCD-S3K with Analog and Digital Outputs

The sensor CYHCD-S3K is a Hall Effect current sensor for the measurement of DC/AC current. The sensor has a galvanic isolation between the high power primary conductor and the secondary electronic circuit. The sensor has an analog and different digital output signals under different power supplies. The data communication between sensor and digital equipment can be realized directly through the interface RS-485 MODBUS.

Features and Advantages	Applications
<ul style="list-style-type: none"> • DC/AC current measurement • High measuring accuracy • Analog output voltage $5VDC \pm 2.5 \times \sqrt{2}$ VAC • Digital outputs (RS-485 Modbus) • High isolation between primary and secondary circuits • No insertion losses 	<ul style="list-style-type: none"> • Photovoltaic equipment • Battery banks, such as, monitoring load current and charge current, verifying operation • Transportation, measuring traction power • Phase fired controlled heaters • Directly connect to PLC • Sense motor stalls and short circuits • Industrial instrumentation

1. Specifications

Analog Electrical Data:

Rated input current (RMS+DC)	25A,30A,40A,50A,60A,70A,80A,90A,100A,200A,300A,400A,500A (The sum of the DC instantaneous value and the AC rms value should not be more than the rated current)
Linear measuring range	1.2 times of rated input current
instantaneous output voltage	$5VDC \pm 2.5 \times \sqrt{2}$ VAC for sinusoid signal
Power supply	+12V DC, +15VDC, +24V DC
Measuring accuracy	$\pm 1.0\%$ FS for 25A~49A; $\pm 0.5\%$ FS for 50A~500A
Linearity (10% - 100%), 25°C	$\pm 0.5\%$ FS for 25A~49A, $\pm 0.2\%$ FS for 50A~500A
Zero offset voltage	± 10 mV
Hysteresis error	± 10 mV
Thermal drift of offset voltage	≤ 300 ppm/°C
Thermal Drift (-10°C to 50°C)	≤ 1000 ppm/°C
Galvanic isolation	3 kV DC, 1min.
Isolation resistance	≥ 100 MΩ
Response time	≤ 10 μs for instantaneous output
Frequency Bandwidth (-3dB)	45Hz – 65Hz
di/dt following accuracy	50A/μs
Overload capacity	5 times of rated current
Current consumption	≤ 25 mA
Output load	≥ 2 kΩ

General Data:

Mounting	35mm DIN Rail
Case style and Window size	WS3 with aperture Ø20mm
Protection of Case	IP20
Operating temperature	-40°C ~ +70°C

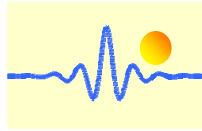

Storage temperature	-40°C ~ +70°C
Relative humidity	5%~95% no dew
MTBF	≥ 100k hours

Digital Electrical Data:

Digital outputs	Current I (RMS value with 2 decimal places in binary code) Frequency F (real frequency with 3 decimal places in binary code)
Output interface:	RS-485, MODBUS
Baud rate:	1200, 2400, 4800, 9600 (default), 19.2K, 38.4K, 57.6K, 115.2K bps
Refreshing period	5ms
Measuring accuracy	±0.5%FS
Linearity (10% - 100%), 25°C	±0.2%FS
Galvanic isolation	2500V rms for 1 min. per UL 1577
Bus protection	±15kV ESD protection on RS-485 input/output pins, open- and short circuit, fail-safe receiver inputs
Power consumption	<650mW (under power supply +12V)

2. Definition of Part number

CYHCD	-	S3K	-	m	-	x	n	y
(1)		(2)		(3)		(4)	(5)	(6)

(1)	(2)	(3)	(4)	(5)	(6)
Series name	Case style	Rated input current (m RMS)	Analog output voltage	Power supply	Interface
CYHCD	S3K	m = 25A, 30A, 40A, 50A, 60A, 70A, 80A, 90A, 100A, 200A, 300A, 400A, 500A	x=3: 5VDC ±2.5x√2 VAC	n=2: +12V DC n=3: +15V DC n=4: +24V DC	x=3: RS485, MODBUS

Example: CYHCD-S3K-50A-323 for AC Current Sensor with
 Rated input current: 0±50A AC
 Analog output voltage: 5VDC±2.5x√2 VAC
 Power supply: +12V DC
 Interface: RS-485, MODBUS

Relation between Input and Output:

Sensor CYHCD-S3K-50A-323	
Input current (A) (instantaneous value)	Output voltage (V) instantaneous value)
-50√2	5 - 2.5x√2
-25√2	5 - 1.25x√2
0	5
25√2	5 + 1.25x√2
50√2	5 + 2.5x√2

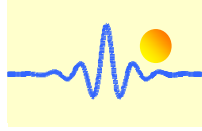

3. Case Style and Connection

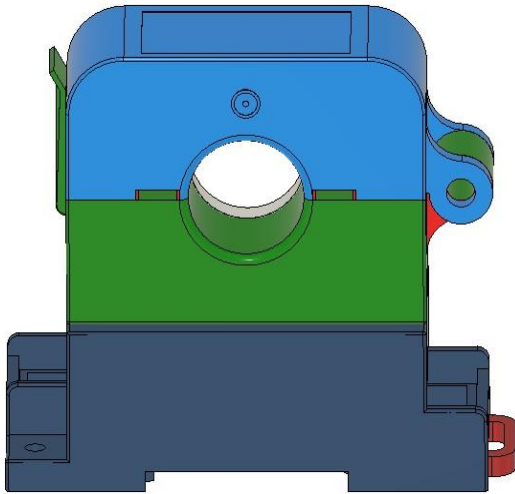

Case S3 with aperture $\varnothing 20\text{mm}$

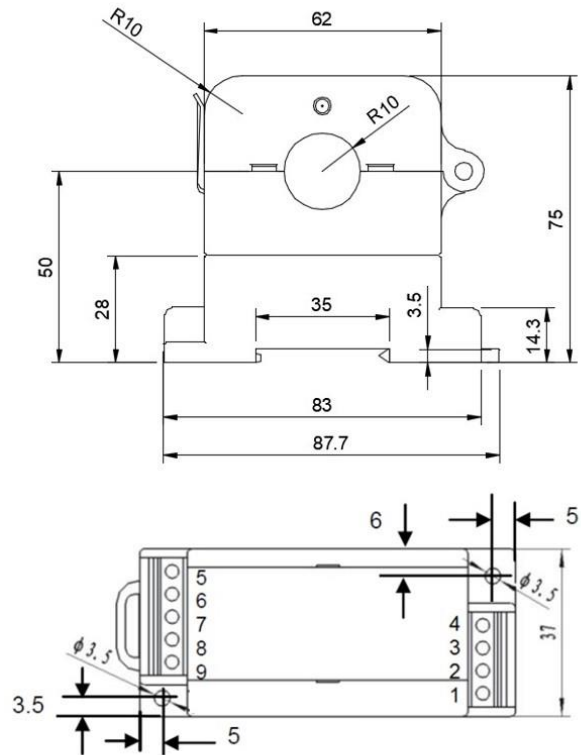

83 x 37 x 75mm

Connection to Master Equipment with RS-485 interface

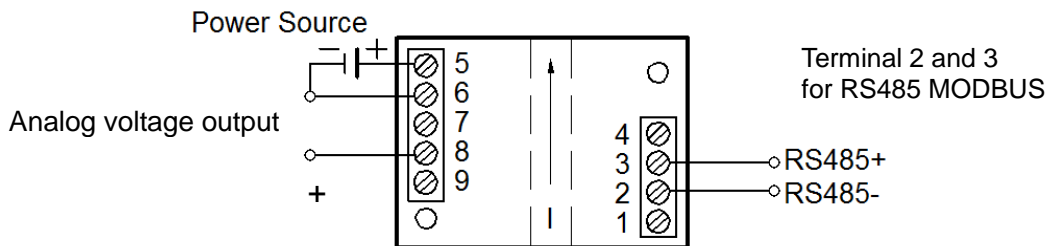

Wiring of Terminals for voltage output:

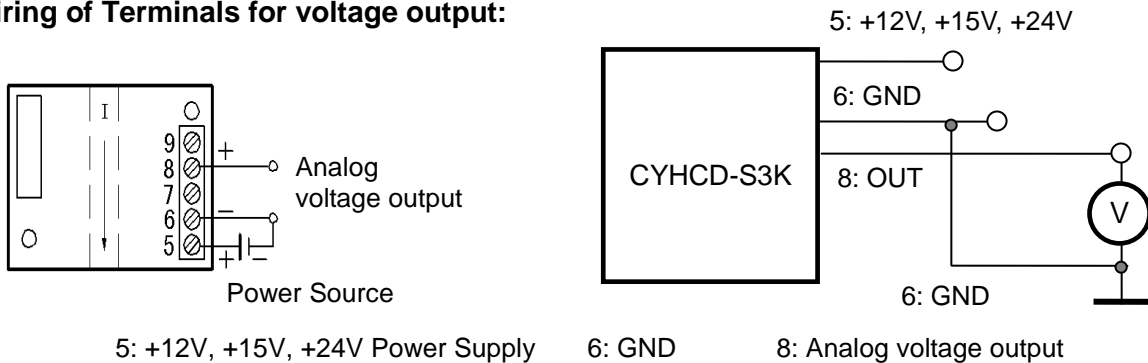

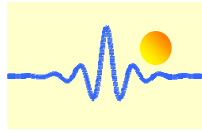

4. Communication Protocol and Order Sets

The orders of the digital Hall Effect current sensor series CYHCD are MODBUS format. Their output communication protocol is RS-485 interface protocol.

4.1 Register Address Table

Register Address	Content	Register Number	R/W	Data Range
0x0010	DC Current	1	R	According to measuring range
0x0011	AC Current	1	R	According to measuring range
0x0012-0x0018	Reserved	7		
0x0019	Frequency	1	R	45000~65000
0x001A-0x001F	Reserved	6		
0x0020	Address and baud rate	1	R/W	Address 0x01-0xF7 Baud rate 0x03-0x0A
0x0021	Device name	2	R	"CDSK"
0x0023	Serial data format	1	R/W	Parity check 0x00-0x02 Length of stop bit 0x00-0x02
0x0024	Internal output low-pass filter cutoff frequency*10	1	R/W	1-10000
0x0025-0x002F	Reserved	11		

Notice: 0x means the number is hex number, same as below.

4.2 Frame Format and Example

4.2.1 Function code 0x03 --- read data from digital sensors

Request frame of master equipment

Sensor address	(0x01-0xF7	1 byte)
Function code	(0x03	1 byte)
Start register address	(2 bytes)	
Register number	(2 bytes)	
CRC	(2 bytes)	

Notice: CRC means Cyclic Redundancy Check. In this product CRC is calculated according to CRC-16 (Modbus) standard, same as below.

Examples:

(1) Read current value (RMS)

DC current:

Address	Function	Register Address	Register Number	CRC-L	CRC-H
0x01	0x03	0x00 0x10	0x00 0x01	0x85	0xCF

AC current:

Address	Function	Register Address	Register Number	CRC-L	CRC-H
0x01	0x03	0x00 0x11	0x00 0x01	0xD4	0x0F

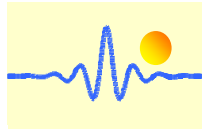

(2) Read frequency value

Address	Function	Register Address		Register Number		CRC-L	CRC-H
0x01	0x03	0x00	0x19	0x00	0x01	0x55	0xCD

(3) Read device name and settings

Address	Function	Register Address		Register Number		CRC-L	CRC-H
0x01	0x03	0x00	0x20	0x00	0x05	0x84	0x03

Answer frame of digital sensors

Sensor address	(0x01-0xF7	1 byte)
Function code	(0x03	1 byte)
Data byte length	(2*register number	1 byte)
Data read from register	(Register contents	2*register number bytes)
CRC	(2 bytes)	

Examples:

(1) Received current value

Address	Function	Data byte length	Data		CRC-L	CRC-H
0x01	0x03	0x02	0x0B	0xB8	0xBF	0x06

Current value format

2 bytes data in binary code with 2 decimal places, original code by positive values, twos complement code by negative values
Data range 0~3000 (measuring range is 30A as an example)

Signification: Data 3000 corresponds positive input with rated RMS value. E.g. when input current equals 30A AC, expected output result is 3000 or 0x0BB8; when input current equals 15A AC, expected output result is 1500 or 0x05DC

(2) Received frequency value

Address	Function	Length	Data		CRC-L	CRC-H
0x01	0x03	0x02	0xC3	0x50	0xE8	0x88

Frequency value format

2 bytes data in binary code with 3 decimal places
Data range 45000~65000

Signification: Data/1000 is the real frequency. E.g. when input current frequency equals 50 Hz, expected output result is 50000 or 0xC350.

(3) Received device name and settings

Address	Function	Length	Data				CRC-L	CRC-H
0x01	0x03	0x0A	0x0106	0x43535333	0x0000	0x0000	0x71	0x94

Explanation:

0x0106 is sensor address and baud rate.

Valid addresses: 0x01 to 0xF7

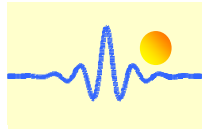

Baud rate: 0x03 -- 1200 bps, 0x04 -- 2400 bps, 0x05 -- 4800 bps,
0x06 -- 9600 bps (default), 0x07 -- 19.2 kbps,
0x08 -- 38.4 kbps, 0x09 -- 57.6 kbps, 0x0A -- 115.2kbps

0x43535333 is the ASCII code of "CSS3".

0x0000 is parity check and length of stop bit.

Parity check: 0x00 -- none (default), 0x01 -- odd, 0x02 -- even

Length of stop bit: 0x00 -- 1 bit (default), 0x01 -- 1.5 bits, 0x02 -- 2 bits

0x0000 is the cutoff frequency of internal output low-pass filter.

Internal low-pass filter cutoff frequency: 0 -- no low-pass filter (default),
others -- cutoff frequency*10

4.2.2 Function code 0x10 --- write data to digital sensors

Request frame of master equipment

Sensor address	(0x01-0xF7	1 byte)
Function code	(0x10	1 byte)
Start register address	(2 bytes)	
Register number	(2 bytes)	
Data byte length	(2*register number	1 byte)
Data write to register	(2*register number bytes)	
CRC	(2 bytes)	

Examples:

(1) Change address and baud rate

Address from 01 (default) to 02, baud rate from 9600 (default) to 19.2K.

Address	Function	Register Address		Register Number		Data Number	Data		CRC-L	CRC-H
0x01	0x10	0x00	0x20	0x00	0x01	0x02	0x02	0x07	0xE1	0x92

Explanation:

Data 0x0207 is written into register 0x0020. The high byte 0x02 means the sensor address on the RS485 bus. The low byte 0x07 means the baud rate of communication.

(2) Change serial data format

Parity check from none (default) to even, length of stop bit from 1 bit (default) to 2 bits.

Address	Function	Register Address		Register Number		Data Number	Data		CRC-L	CRC-H
0x01	0x10	0x00	0x23	0x00	0x01	0x02	0x02	0x02	0x21	0xA2

Explanation:

Data 0x0202 is written into register 0x0023. The high byte 0x02 means the parity check. The low byte 0x02 means the length of stop bit.

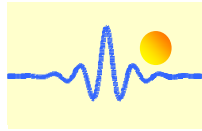

(3) Change cutoff frequency of internal output low-pass filter

From no low-pass filter (default) to cutoff frequency 65.5Hz.

Address	Function	Register Address		Register Number		Data Number	Data		CRC-L	CRC-H
0x01	0x10	0x00	0x24	0x00	0x01	0x02	0x02	0x8F	0xE0	0x70

Explanation:

This current sensor has a first order digital low-pass filter for output, which keeps the output result with higher stability when cutoff frequency is low. But a lower cutoff frequency also causes slower response. User can turn off this low-pass filter or adjust the cutoff frequency by setting this register.

Please note that this low pass filter is not directly applied to the input signal. So it doesn't cause additional attenuation of amplitude. But the output response is slower, when the input RMS value variants.

Data 0x028F is written into register 0x0024. 0x028F=655, which corresponds cutoff frequency 65.5Hz.

Answer frame of digital sensors

Sensor address	(0x01-0xF7)	1 byte)
Function code	(0x10)	1 byte)
Start register address	(2 bytes)	
Register number	(2 bytes)	
CRC	(2 bytes)	

Examples:

(1) Received correct answer of changing address and baud rate

Address	Function	Register Address		Register Number		CRC-L	CRC-H
0x01	0x10	0x00	0x20	0x00	0x01	0x00	0x03

(2) Received correct answer of changing serial data format

Address	Function	Register Address		Register Number		CRC-L	CRC-H
0x01	0x10	0x00	0x23	0x00	0x01	0xF0	0x03

(3) Received correct answer of changing cutoff frequency

Address	Function	Register Address		Register Number		CRC-L	CRC-H
0x01	0x10	0x00	0x24	0x00	0x01	0x41	0xC2

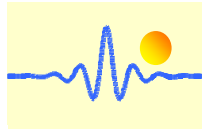

4.2.3 Error frame from digital sensors

Error frame of digital sensors

Sensor address	(0x01-0xF7	1 byte)
Function code	(0x80 function code	1 byte)
Error Code	(0x01-0x04	1 byte)
CRC	(2 bytes)	

The symbol “|” means logic “OR”

Error code

- 0x01: illegal function
- 0x02: illegal register address
- 0x03: illegal data value or register number
- 0x04: sensor failures (read or write error)

Examples:

(1) Wrong function code has been send

For example, the function code 0x04 has been sent in a sending frame. Received error answer is

Address	Function	Error Code	CRC-L	CRC-H
0x01	0x84	0x01	0x82	0xC0

(2) Wrong register address has been send

The sending frame is for reading the current value as showed in paragraph 4.2.1, but the register address is 0x0001. Received error answer is

Address	Function	Error Code	CRC-L	CRC-H
0x01	0x83	0x02	0xC0	0xF1

(3) Wrong register number has been send

The sending frame is for reading device name and settings as showed in paragraph 4.2.1, but the register number is 0x0010. In this situation, the last register address that should be written is 0x0030, which is beyond the valid address range 0x0010-0x002F. Received error answer is

Address	Function	Error Code	CRC-L	CRC-H
0x01	0x83	0x02	0xC0	0xF1

(4) Register number must be greater than 0

The sending frame is for reading the current value as showed in paragraph 4.2.1, but the register number is 0x0000. Received error answer is

Address	Function	Error Code	CRC-L	CRC-H
0x01	0x83	0x03	0x01	0x31

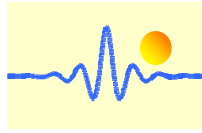

(5) Wrong data number has been send

The sending frame is for changing cutoff frequency as showed in paragraph 4.2.2, but the data number is 0x03, which doesn't match register number*2. Received error answer is

Address	Function	Error Code	CRC-L	CRC-H
0x01	0x90	0x03	0x0C	0x01

(6) Data written is beyond valid data range

The sending frame is for changing device address and baud rate as showed in paragraph 4.2.2, but the data is 0xF807, which is beyond the valid device address range 0x01-0xF7. Received error answer is

Address	Function	Error Code	CRC-L	CRC-H
0x01	0x90	0x03	0x0C	0x01

(7) The case (0x04: Sensor failures) should not occur in this sensor

Notes:

1. If digital sensor address or CRC is wrong, no answer frame or error frame will be back from sensor.
2. Low byte of CRC is transmitted first. By register address, register number and data, high byte is transmitted first.
3. Register word length is 16 bits (2 bytes).
4. Every valid request frame has a corresponding answer. The master equipment should send the next request after the answer has been received. The maximum waiting time for data reading equals to the data refreshing period. And the waiting time for configuration changing is up to 25ms.

Application Notes:

1. Connect the terminals of power source, output respectively and correctly, never make wrong connection.
2. Two potentiometers can be adjusted, only if necessary, by turning slowly to the required accuracy with a small screw driver.
3. The best accuracy can be achieved when the window is fully filled with bus-bar (current carrying conductor).
4. The in-phase output can be obtained when the direction of current of current carrying conductor is the same as the direction of arrow marked on the transducer case.