



AC/DC Current Sensor with Split Core CYHCS-C2

This Hall Effect current sensor is based on open loop principle and can be used for measurement of AC/DC currents.

Product Characteristics	Applications
<ul style="list-style-type: none">• Excellent accuracy• Very good linearity• Split Core, easy installation• Light in weight• Less power consumption• Window structure• Electrically isolating the output of the transducer from the current carrying conductor• No insertion loss• Current overload capability	<ul style="list-style-type: none">• Photovoltaic equipment• Frequency conversion timing equipments• Various power supply• Uninterruptible power supplies (UPS)• Electric welding machines• Transformer substation• Numerical controlled machine tools• Electrolyzing and electroplating equipments• Electric powered locomotive• Microcomputer monitoring• Electric power network monitoring

Electrical Data

Measuring range M	200A ~ 1800A AC/DC
Linearity range	1.5 x M (measuring range)
Overload capacity	20 x M (measuring range)
Nominal output signals	0-4V, 0-5V, 0-10V, 0-20mA, 4-20mA,
Supply voltage	+12VDC, +15VDC, +24VDC, ±12VDC, ±15VDC
Current consumption	25mA ~ 50mA + output current
Galvanic isolation	3KV RMS/50Hz/min

Accuracy and Dynamic Performances

Zero offset voltage	±20	mV
Hysteresis error	±10	mV
Thermal drift of offset current	≤500	ppm/°C
Response time	≤10 (di/dt=50A/μs)	μs
Accuracy	±1.0	%
Linearity	≤1.0	%FS

General Data

Operating temperature	-10 ~ +80	°C
Storage temperature	-25 ~ +85	°C



Definition of Part number:

CYHCS	-	C2	-	m	-	x	n
(1)		(2)		(3)		(4)	(5)

(1)	(2)	(3)	(4)	(5)
Series name	Case style	Rated Input current (m)	Output signal	Power supply
CYHCS	C2	m = 200A, 300A, 400A, 500A, 600A, 700A, 800A, 1000A, 1500A, 1800A	x=0: 0-4V DC (rms) x=1: tracing voltage 5V x=2: tracing current 20mA x=3: 0-5V DC (rms) x=4: 0-20mA DC (rms) x=5: 4-20mA DC (rms) x=8: 0-10V DC (rms)	n=2: +12V DC n=3: +15V DC n=4: +24V DC n=5: ±12V DC n=6: ±15V DC

Example 1: CYHCS-C2-1000A -34, Hall Effect AC Current sensor with
Output signal: 0-5V DC
Power supply: +24V DC
Rated input current: 0-1000A AC

Example 2: CYHCS-C2-B1000A -45, Hall Effect AC Current sensor with
Output signal: 0-20mA DC
Power supply: ±12V DC
Rated input current: 0-1000A AC

DIMENSIONS (mm)

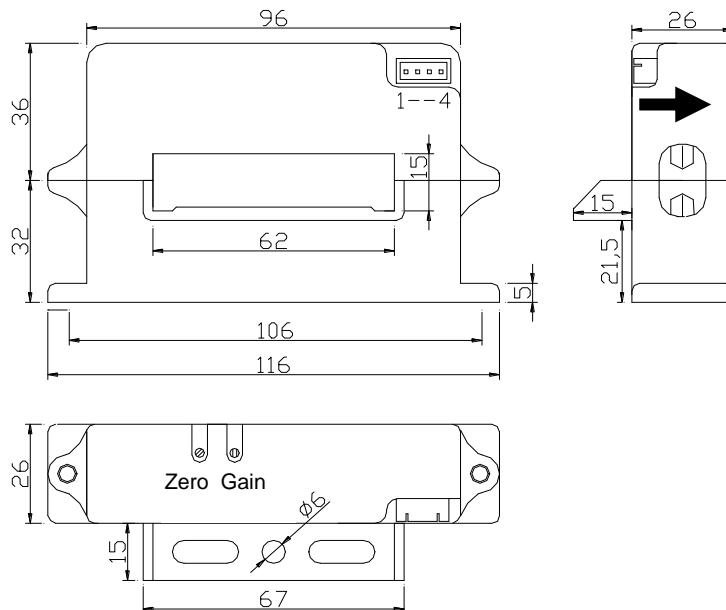

Mounting hole:
Ø6.0mm

Molex Connector





CONNECTION

The current carrying cable must pass through the window. The phase of output is the same as that of the current passing the window in the direction of the arrow indicated on the case.

a) Wiring of Sensors Using Double Power Supplies

Voltage Output

- 1(+): +15V/+12V Power Supply
- 2(-): -15V/-12V Power Supply
- 3(M): Output
- 4(G): Ground

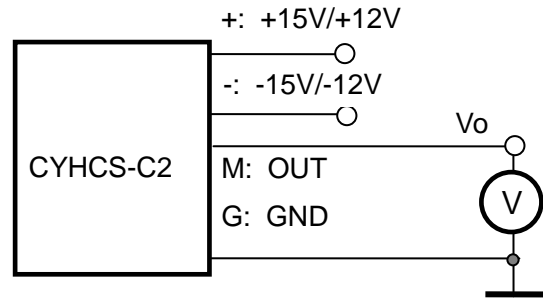

Relation between Input and Output:

Sensor CYHCS-C2-1000A -35	
Input current (A)	Output voltage (V)
0	0
250	1.25
500	2.5
750	3.75
1000	5

Current Output

- 1(+): +15V/+12V Power Supply
- 2(-): -15V/-12V Power Supply
- 3(M): Output
- 4(G): Ground

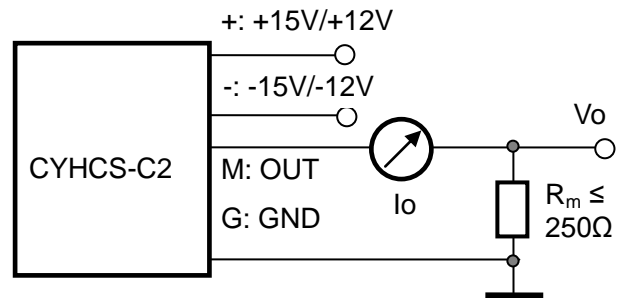

Relation between Input and Output (for $R_m=250 \Omega$):

Sensor CYHCS-C2-1000A -45		
Input current (A)	Output current I_o (mA)	Output voltage V_o (V)
0	0	0
250	5	1.25
500	10	2.5
750	15	3.75
1000	20	5



B) Wiring of Sensors Using Single Power Supply

Voltage Output

1(+): +15V, +12V, +24V
 2(-): NC
 3(M): Output
 4(G): Ground

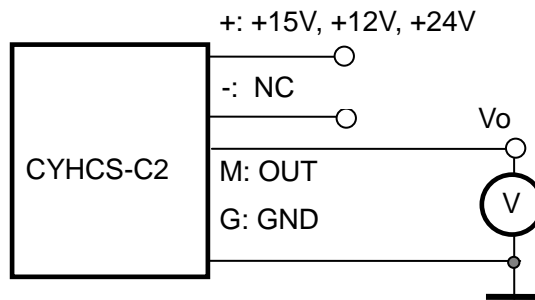

Relation between Input and Output:

Sensor CYHCS-C2-1000A -34	
Input current (A)	Output voltage (V)
0	0
250	1.25
500	2.5
750	3.75
1000	5

Current Output

1(+): +15V, +12V, +24V
 2(-): NC
 3(M): Output
 4(G): Ground

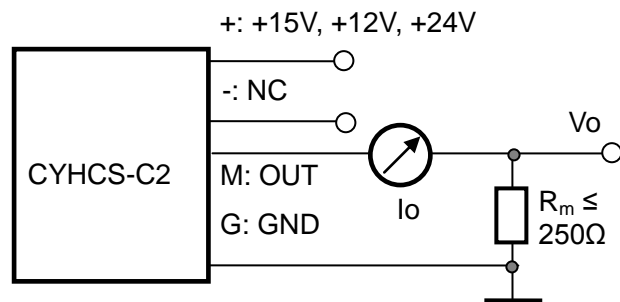

Relation between Input and Output (for $R_m=250 \Omega$):

Sensor CYHCS-C2-1000A -54		
Input current (A)	Output current I_o (mA)	Output voltage V_o (V)
0	4	1
250	8	2
500	12	3
750	16	4
1000	20	5

Notes:

1. Connect the terminals of power source, outputs respectively and correctly, never make wrong connection.
2. Two potentiometers can be adjusted, only if necessary, by turning slowly to the required accuracy with a small screwdriver.
3. The best accuracy can be achieved when the window is fully filled with bus-bar (current carrying conductor).
4. The in-phase output can be obtained when the direction of current of current carrying conductor is the same as the direction of arrow marked on the transducer case.