

AC/DC Split Core Hall Current Sensor CYHCS-C2S

This Hall Effect current sensor can be used for measurement of DC and AC current, pulsed currents etc. The output of the transducer reflects the real wave of the current carrying conductor.

Product Characteristics	Applications
<ul style="list-style-type: none"> • Excellent accuracy • Very good linearity • Light in weight • Less power consumption • Window structure • Electrically isolating the output of the transducer from the current carrying conductor • No insertion loss • Current overload capability 	<ul style="list-style-type: none"> • Frequency conversion timing equipment • Various power supply • Uninterruptible power supplies (UPS) • Electric welding machines • Numerical controlled machine tools • Electrolyzing and electroplating equipment • Electric powered locomotive • Microcomputer monitoring • Electric power network monitoring

Electrical Data

Primary Nominal Current I_r (A)	Primary Current Measuring Range I_p (A) at $V_{cc}=5V$	Output Voltage (analog) (V)	Part number
30	± 40.5	2.5VDC \pm 1.5V	CYHCS-C2S-30A-C
50	± 67.5		CYHCS-C2S-50A-C
100	± 135		CYHCS-C2S-100A-C
200	± 270		CYHCS-C2S-200A-C
300	± 405		CYHCS-C2S-300A-C
400	± 540		CYHCS-C2S-400A-C
500	± 675		CYHCS-C2S-500A-C
600	± 810		CYHCS-C2S-600A-C

(Connector: Molex connector C=M; Phoenix Connector: C=P)

Supply Voltage

$V_{cc} = +5V \pm 5\%$

Current Consumption

$I_c < 25mA$

RMS Voltage for 2.5kV AC isolation test, 50/60Hz, 1min,

$V_{is} < 10mA$

Output Impedance:

$R_{out} < 150\Omega$

Load Resistance:

$R_L > 10k\Omega$

Accuracy at I_r , $T_A=25^\circ C$ (without offset),

$X < 1.0\%$

Linearity from 0 to I_r , $T_A=25^\circ C$,

$E_L < 1.0\% FS$

Electric Offset Voltage, $T_A=25^\circ C$,

$V_{oe} = 2.5VDC \pm 1.0\%$

Magnetic Offset Voltage ($I_r \rightarrow 0$)

$V_{om} < \pm 15mV$

Thermal Drift of Offset Voltage,

$V_{ot} < \pm 1.0mV/^\circ C$

Thermal Drift (-10 $^\circ C$ to 50 $^\circ C$),

T.C. $< \pm 0.1\% /^\circ C$

Response Time at 90% of I_p ($f=1k Hz$)

$t_r < 7\mu s$

Frequency Bandwidth (-3dB),

$f_b = 0-20 kHz$

General Data

Ambient Operating Temperature,

$T_A = -25^\circ C \sim +85^\circ C$

Ambient Storage Temperature,

$T_S = -40^\circ C \sim +100^\circ C$

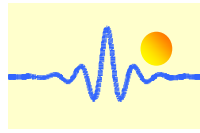

Relation between Input Current and Output Voltage

Take the sensor CYHCS-C2S-100A as sample, the relation between the input current and output voltage is shown in the table 1, Fig.1 and Fig. 2

Table 1. Relation between the input current and output voltage

Input current (A)	-135	-100	-75	-50	0	50	75	100	135
Output voltage (V)	0.475	1.0	1.375	1.75	2.5	3.25	3.625	4.0	4.525

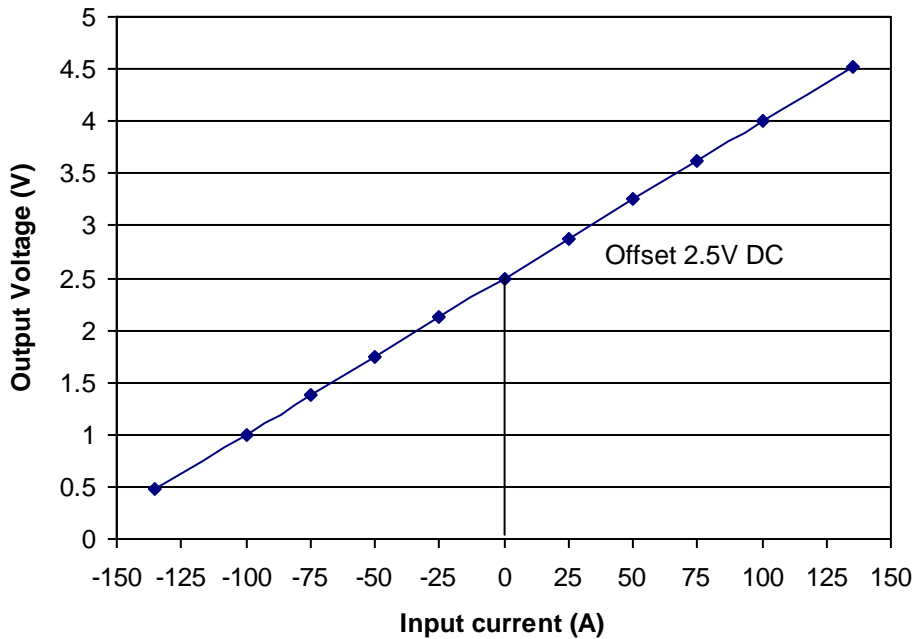

Fig. 1 Relation between the input current (DC) and output voltage (DC)

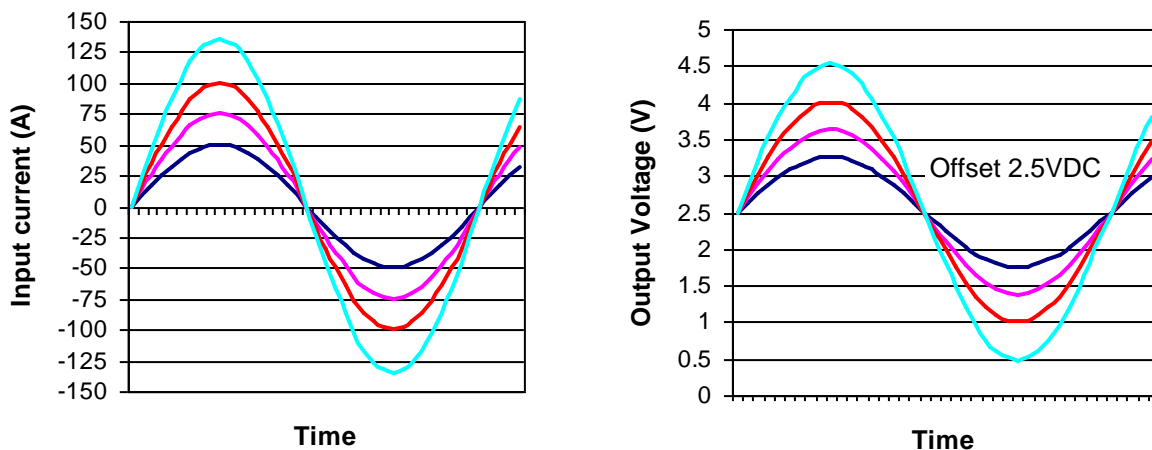
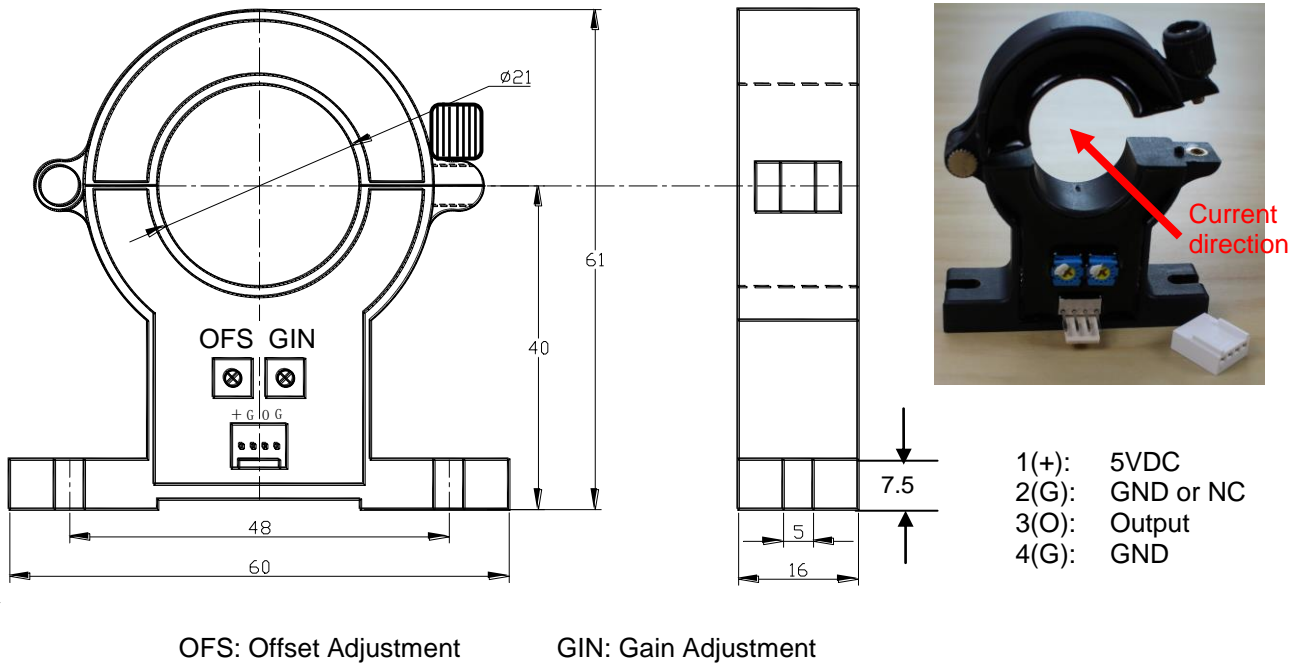
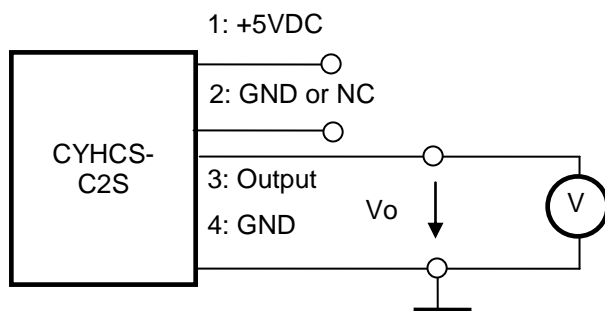

Fig. 2 Relation between the input current (AC) and output voltage (AC)

PIN Definition and Dimensions



Connection



Notes:

1. Connect the terminals of power source, output respectively and correctly, never make wrong connection.
2. Two potentiometers can be adjusted, only if necessary, by turning slowly to the required accuracy with a small screwdriver.
3. The best accuracy can be achieved when the window is fully filled with bus-bar (current carrying conductor).
4. The in-phase output can be obtained when the direction of current of current carrying conductor is the same as the direction of arrow marked on the transducer

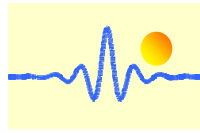

DIN Rail Adapter CY-DRA88

The DIN Rail Adapter CY-DRA88 is designed for mounting the sensor on 35mm DIN Rail. It has the size 70 x 24 x 23mm. The height from bottom to mounting surface is 14.8mm.

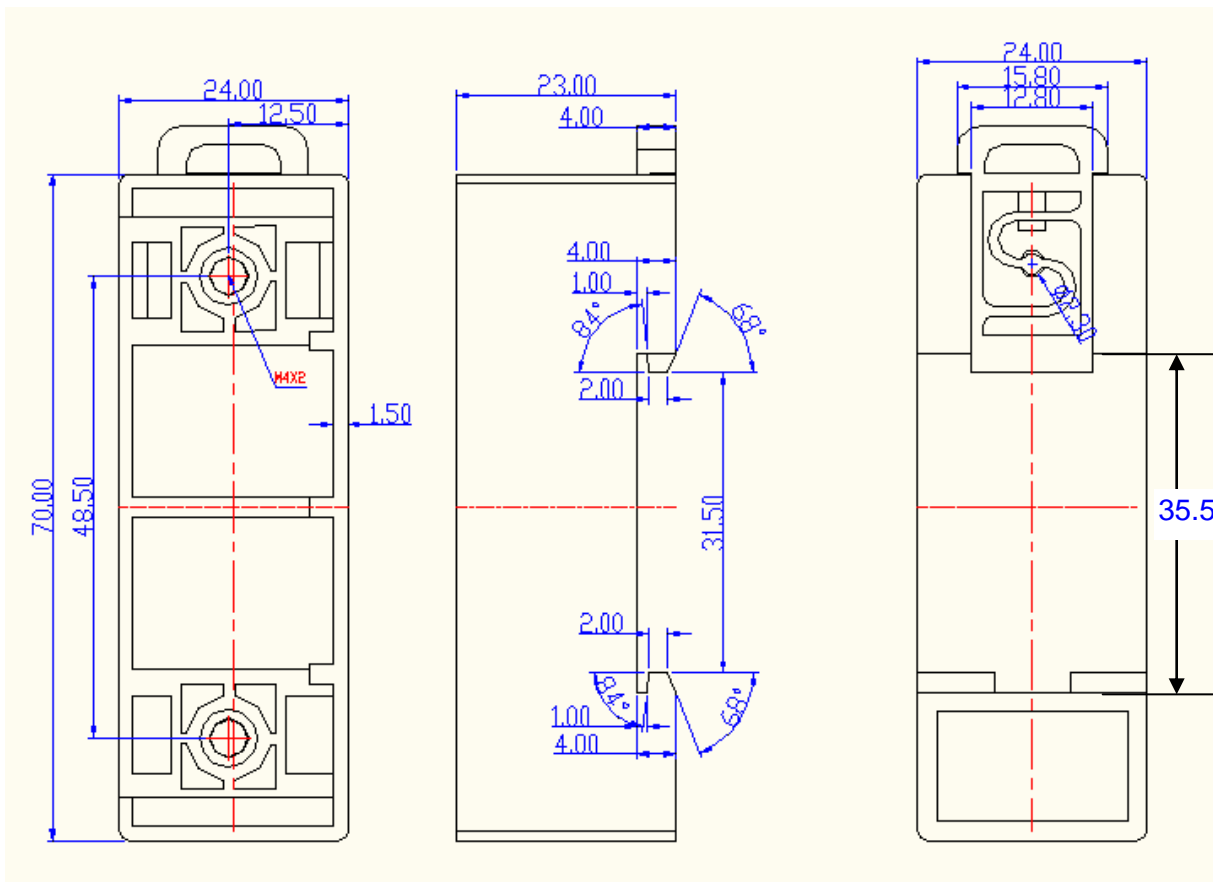
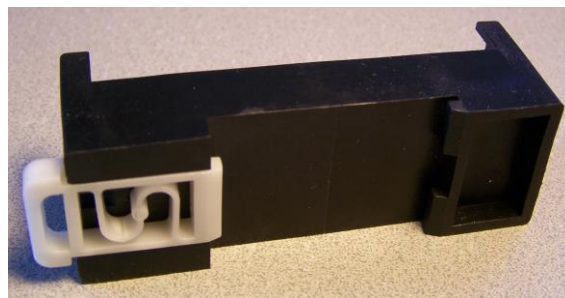

Mounting of Sensors



Sensor with Molex Connector
(The distance between the bottom und the middle of hole is 54.8mm)



Sensor with Phoenix Connector
(The distance between the bottom und the middle of hole is 54.8mm)