

## Hall Effect AC/DC Current Sensor CYHCS-ED

This Hall Effect current sensor is based on open loop principle and designed with a solid core and a high galvanic isolation between primary conductor and secondary circuit. It can be used for measurement of AC/DC current etc. The output of the transducer reflects the real wave of the current carrying conductor. It can be mounted on the primary cable directly.

Product Characteristics	Applications
<ul style="list-style-type: none"> <li>• Excellent accuracy</li> <li>• Very good linearity</li> <li>• Light in weight</li> <li>• Less power consumption</li> <li>• Window structure, easily mounting</li> <li>• Electrically isolating the output of the transducer from the current carrying conductor</li> <li>• No insertion loss</li> <li>• Current overload capability</li> </ul>	<ul style="list-style-type: none"> <li>• Photovoltaic equipment</li> <li>• Frequency conversion timing equipment</li> <li>• Various power supply</li> <li>• Uninterruptible power supplies (UPS)</li> <li>• Electric welding machines</li> <li>• Numerical controlled machine tools</li> <li>• Electrolyzing and electroplating equipment</li> <li>• Electric powered locomotive</li> <li>• Microcomputer monitoring</li> <li>• Electric power network monitoring</li> </ul>

### Electrical Data/Input

Primary Nominal Current $I_r$ (A)	Primary Current Measuring Range $I_p$ (A)	Output Voltage (Analog) (V)	Part number
30A	0 ~ ± 60A	4 ±1.0%	CYHCS-ED-30A
40A	0 ~ ± 80A		CYHCS-ED-40A
50A	0 ~ ± 100A		CYHCS-ED-50A
100A	0 ~ ± 200A		CYHCS-ED-100A
200A	0 ~ ± 400A		CYHCS-ED-200A
300A	0 ~ ± 600A		CYHCS-ED-300A
400A	0 ~ ± 800A		CYHCS-ED-400A
500A	0 ~ ± 1000A		CYHCS-ED-500A
600A	0 ~ ± 1200A		CYHCS-ED-600A

Supply Voltage:  
Current Consumption  
Isolation Voltage

$V_{cc} = \pm 15\text{VDC} \pm 5\%$   
 $I_c < 20\text{mA}$   
2,5kV, 50/60Hz, 1min

### Electrical Data/Output

Output Voltage at  $I_r$ ,  $T_A = 25^\circ\text{C}$ :  
Output Impedance:  
Load Resistor:

$V_{out} = 4\text{VDC}$   
 $R_{out} < 150\Omega$   
 $R_L > 10\text{k}\Omega$

### Accuracy

Accuracy at  $I_r$ ,  $T_A = 25^\circ\text{C}$  (without offset),  
Linearity from 0 to  $I_r$ ,  $T_A = 25^\circ\text{C}$ ,  
Electric Offset Voltage,  $T_A = 25^\circ\text{C}$ ,  
Magnetic Offset Voltage ( $I_r \rightarrow 0$ )  
Thermal Drift of Offset Voltage,  
Thermal Drift ( $-10^\circ\text{C}$  to  $50^\circ\text{C}$ ),  
Response Time at 90% of  $I_p$  ( $f = 1\text{k Hz}$ )  
Frequency Bandwidth (-3dB),

$X < 1.0\%$   
 $E_L < 1.0\% \text{ FS}$   
 $V_{oe} < \pm 25\text{mV}$   
 $V_{om} < \pm 20\text{mV}$   
 $V_{ot} < \pm 1.0\text{mV}/^\circ\text{C}$   
T.C.  $< \pm 0.1\% / ^\circ\text{C}$   
 $t_r < 7\mu\text{s}$   
 $f_b = \text{DC-20 kHz}$

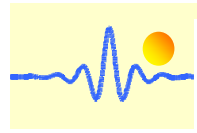

## General Data

Ambient Operating Temperature,  
Ambient Storage Temperature,  
Unit weight:

$T_A = -25^{\circ}\text{C} \sim +85^{\circ}\text{C}$   
 $T_S = -40^{\circ}\text{C} \sim +100^{\circ}\text{C}$   
60g /unit

## PIN Definition and Dimensions

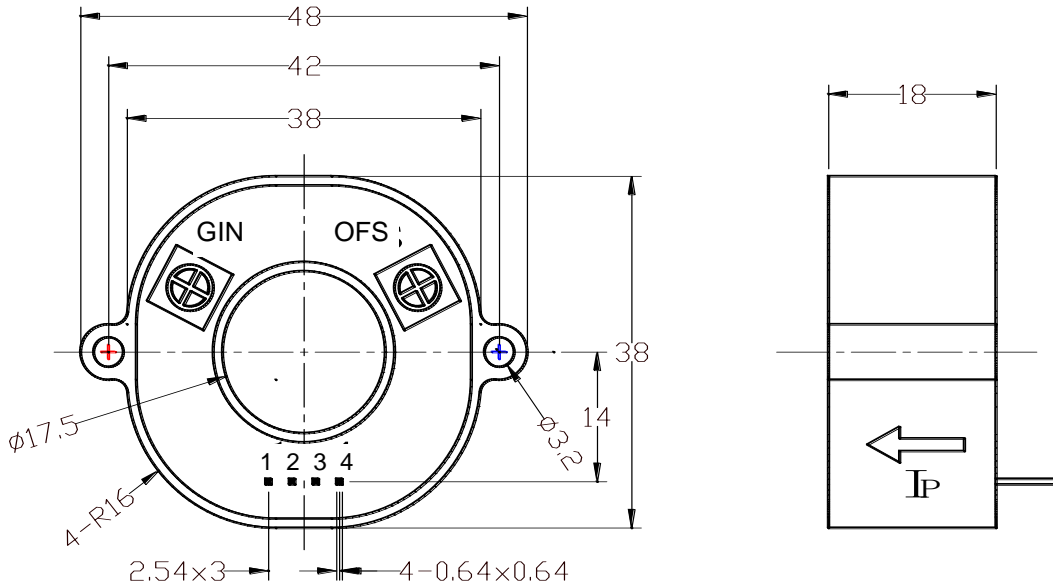

OFS: Offset Adjustment

GIN: Gain Adjustment

### Pin arrangement:

1 (V+):	Vcc	2 (V-):	-Vcc
3 (OUT):	OUTPUT	4 (GND):	0V (GND)

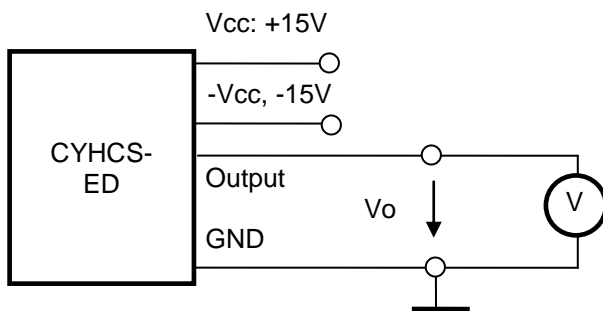

## Notes:

1. Connect the terminals of power source, output respectively and correctly, never make wrong connection.
2. Two potentiometers can be adjusted, only if necessary, by turning slowly to the required accuracy with a small screwdriver.
3. The best accuracy can be achieved when the window is fully filled with bus-bar (current carrying conductor).
4. The in-phase output can be obtained when the direction of current of current carrying conductor is the same as the direction of arrow marked on the transducer