

Split Core Hall AC/DC Current Sensor CYHCS-EKAA

This Hall Effect current sensor is based on open loop principle and designed with a split core and a high galvanic isolation between primary conductor and secondary circuit. It can be used for measurement of DC and AC current, pulse currents etc. The output of the transducer reflects the real wave of the current carrying conductor.

Product Characteristics	Applications
<ul style="list-style-type: none"> • Excellent accuracy • Very good linearity • Using split cores and easy mounting • Less power consumption • Window structure • Electrically isolating the output of the transducer from the current carrying conductor • No insertion loss • Current overload capability 	<ul style="list-style-type: none"> • Photovoltaic equipment • Frequency conversion timing equipment • Various power supply • Uninterruptible power supplies (UPS) • Electric welding machines • Transformer substation • Numerical controlled machine tools • Electric powered locomotive • Microcomputer monitoring • Electric power network monitoring

Electrical Data

Primary Nominal Current I_r (A)	Measuring Range (A)	Output Current I_s (analog) (mA)	Aperture Diameter (mm)	Part number
30	± 60	0 ~20mA $\pm 1.0\%$	$\varnothing 21$	CYHCS-EKAA30A-C
50	± 100			CYHCS-EKAA50A-C
100	± 200			CYHCS-EKAA100A-C
200	± 400			CYHCS-EKAA200A-C
300	± 600			CYHCS-EKAA300A-C
400	± 800			CYHCS-EKAA400A-C
500	± 1000			CYHCS-EKAA500A-C

(Connector: Molex connector C=M; Phoenix Connector: C=P)

Supply Voltage
Current Consumption
Galvanic isolation, 50/60Hz, 1min:
Load resistance:
Isolation resistance @ 500 VDC

$V_{cc} = \pm 15V \pm 5\%$,
 $I_c < 25mA + I_s$
2.5kV
10k Ω
> 500 M Ω

Accuracy and Dynamic performance data

Accuracy at I_r , $T_A=25^\circ\text{C}$ (without offset),
Linearity from 0 to I_r , $T_A=25^\circ\text{C}$,
Electric Offset Voltage, $T_A=25^\circ\text{C}$,
Magnetic Offset Voltage, $T_A=25^\circ\text{C}$,
Thermal Drift of Offset Voltage,
Response Time at 90% of I_P ($f=1\text{k Hz}$)
Frequency bandwidth (- 3 dB):

$X < 1.0\%$
 $E_L < 1.0\% \text{ FS}$
 $V_{oe} < 0.05\text{mA}$
 $V_{oe} < 0.05\text{mA}$
 $V_{ot} \leq \pm 0.01\text{mA}/^\circ\text{C}$
 $t_r < 5\mu\text{s}$
20Hz - 20kHz

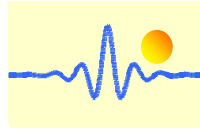

General Data

Ambient Operating Temperature,
Ambient Storage Temperature,

$T_A = -25^{\circ}\text{C} \sim +85^{\circ}\text{C}$
 $T_S = -40^{\circ}\text{C} \sim +100^{\circ}\text{C}$

PIN Definition and Dimensions

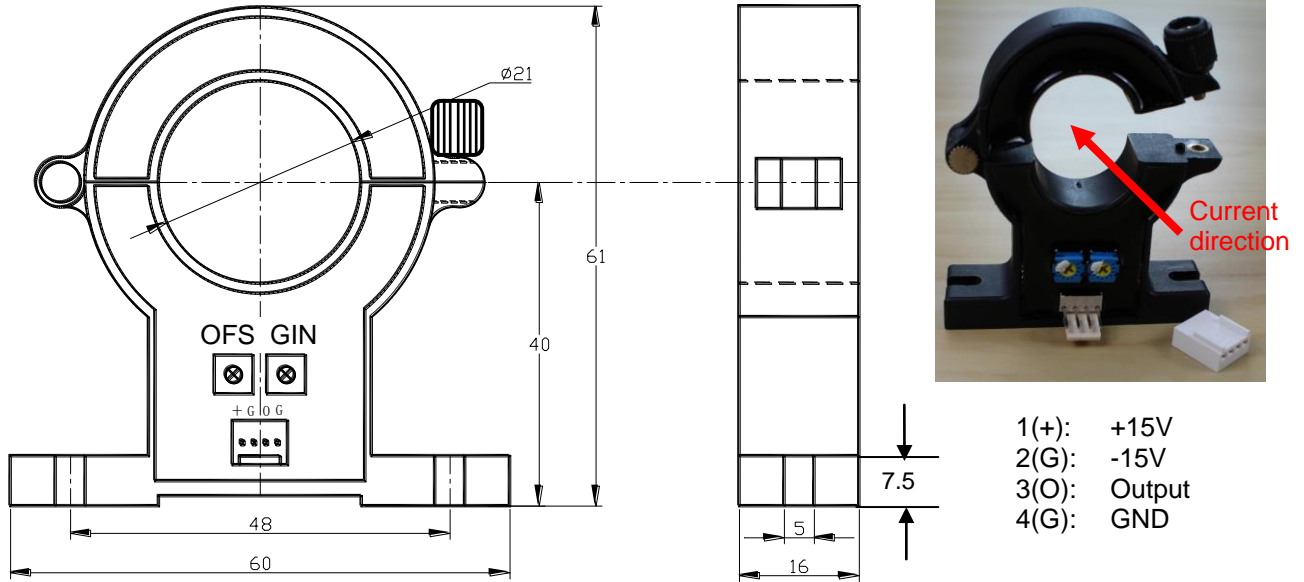

OFS: Offset Adjustment

GIN: Gain Adjustment

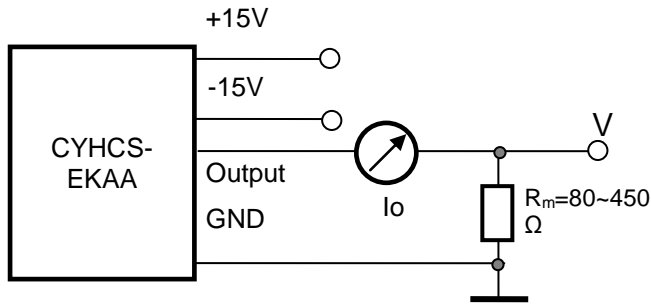

Notes:

1. Connect the terminals of power source, output respectively and correctly, never make wrong connection.
2. Two potentiometers can be adjusted, only if necessary, by turning slowly to the required accuracy with a small screwdriver.
3. The best accuracy can be achieved when the window is fully filled with bus-bar (current carrying conductor).
4. The in-phase output can be obtained when the direction of current of current carrying conductor is the same as the direction of arrow marked on the transducer

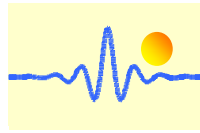

DIN Rail Adapter CY-DRA88

The DIN Rail Adapter CY-DRA88 is designed for mounting the sensor on 35mm DIN Rail. It has the size 70 x 24 x 23mm. The height from bottom to mounting surface is 14.8mm.

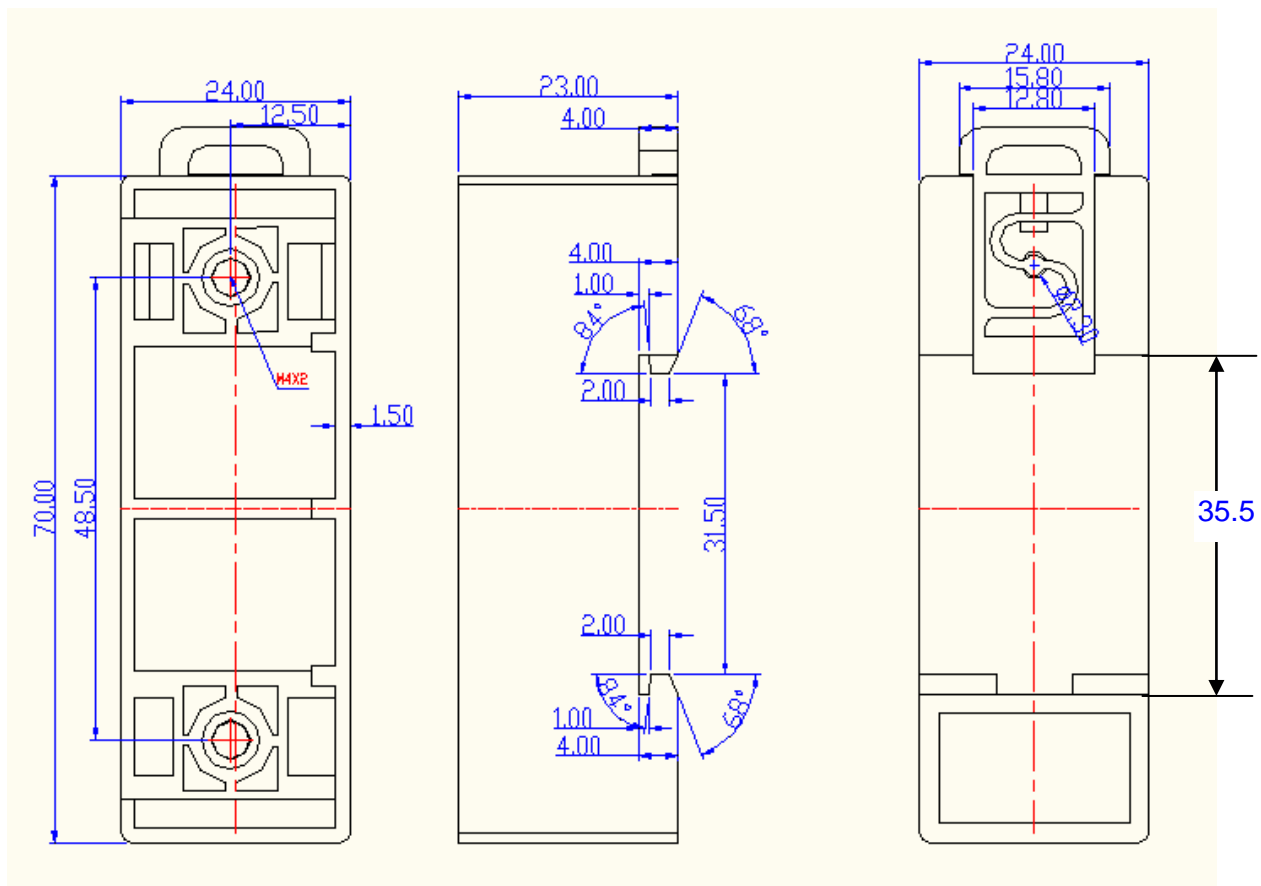
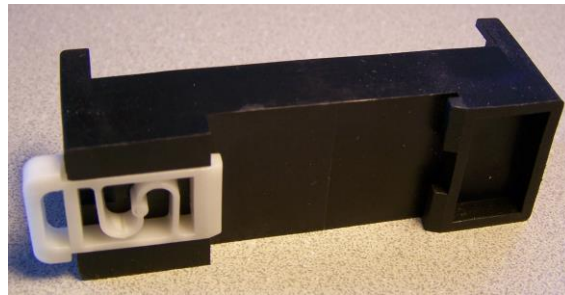

Mounting of Sensors



Sensor with Molex Connector
(The distance between the bottom und the middle of hole is 54.8mm)



Sensor with Phoenix Connector
(The distance between the bottom und the middle of hole is 54.8mm)