

## Split Core Hall AC/DC Current Sensor CYHCS-EKB

This Hall Effect current sensor is based on open loop principle and designed with a split core and a high galvanic isolation between primary conductor and secondary circuit. It can be used for measurement of DC and AC current, pulse currents etc. The output of the transducer reflects the real wave of the current carrying conductor.

Product Characteristics	Applications
<ul style="list-style-type: none"> <li>• Excellent accuracy</li> <li>• Very good linearity</li> <li>• Using split cores and easy mounting</li> <li>• Less power consumption</li> <li>• Window structure</li> <li>• Electrically isolating the output of the transducer from the current carrying conductor</li> <li>• No insertion loss</li> <li>• Current overload capability</li> </ul>	<ul style="list-style-type: none"> <li>• <b>Photovoltaic equipment</b></li> <li>• Frequency conversion timing equipment</li> <li>• Various power supply</li> <li>• Uninterruptible power supplies (UPS)</li> <li>• Electric welding machines</li> <li>• Transformer substation</li> <li>• Numerical controlled machine tools</li> <li>• Electric powered locomotive</li> <li>• Microcomputer monitoring</li> <li>• Electric power network monitoring</li> </ul>

### Electrical Data (all data given under connecting a load resistance of 10kΩ)

Primary Nominal Current $I_r$ (A)	Measuring Range (A)	Output voltage (Analog) (V)	Aperture Diameter (mm)	Part number
50	± 100	4 ±1.0%	Ø40.5	CYHCS-EKB50A-C
100	± 200			CYHCS-EKB100A-C
200	± 400			CYHCS-EKB200A-C
400	± 800			CYHCS-EKB400A-C
500	± 1000			CYHCS-EKB500A-C
800	± 1600			CYHCS-EKB800A-C
1000	± 2000			CYHCS-EKB1000A-C
2000	± 3000			CYHCS-EKB2000A-C

(Connector: Molex connector C=M; Phoenix Connector: C=P)

Supply Voltage  
Current Consumption  
Galvanic isolation, 50/60Hz, 1min:  
Load resistance:  
Isolation resistance @ 500 VDC

$V_{cc} = \pm 12V \sim 15VDC$   
 $I_c < 25mA$   
5kV  
10kΩ  
> 500 MΩ

### Accuracy and Dynamic performance data

Accuracy at  $I_r$ ,  $T_A = 25^\circ C$  (without offset),  
Linearity from 0 to  $I_r$ ,  $T_A = 25^\circ C$ ,  
Electric Offset Voltage,  $T_A = 25^\circ C$ ,  
Magnetic Offset Voltage ( $I_r \rightarrow 0$ )  
Thermal Drift of Offset Voltage,  
Thermal Drift ( $-10^\circ C$  to  $50^\circ C$ ),  
Response Time at 90% of  $I_P$  ( $f = 1k$  Hz)  
Frequency bandwidth (-3 dB):

$X < 1.0\%$   
 $E_L < 1.0\% FS$   
 $V_{oe} < 20mV$   
 $V_{om} < \pm 20mV$   
 $V_{ot} < \pm 0.5mV/^\circ C$   
T.C. <  $\pm 0.1\% / ^\circ C$   
 $t_r < 5\mu s$   
DC-20kHz

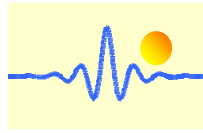

## General Data

Ambient Operating Temperature,  
Ambient Storage Temperature,

$T_A = -25^{\circ}\text{C} \sim +85^{\circ}\text{C}$   
 $T_S = -40^{\circ}\text{C} \sim +100^{\circ}\text{C}$

## PIN Definition and Dimensions

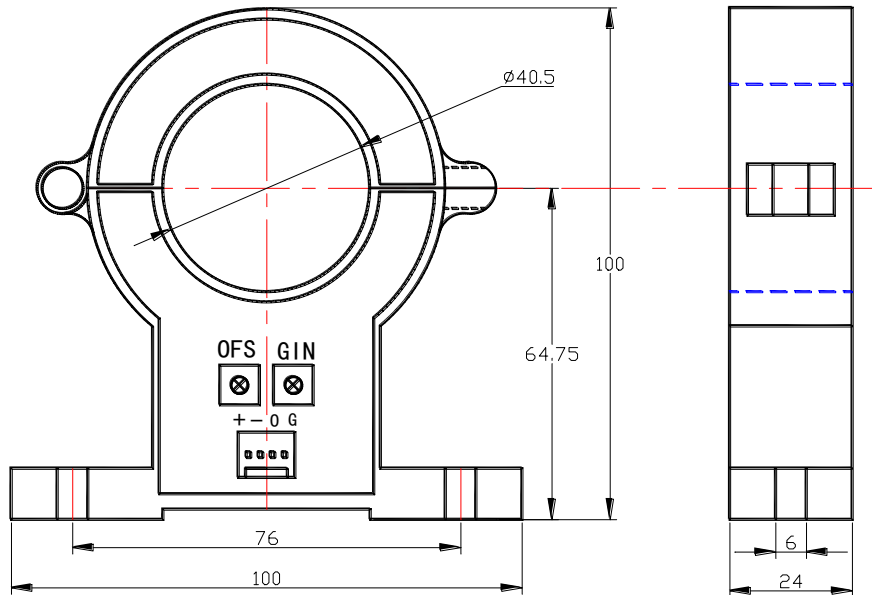

+: +15V  
-: -15V  
O: Output  
G: Ground

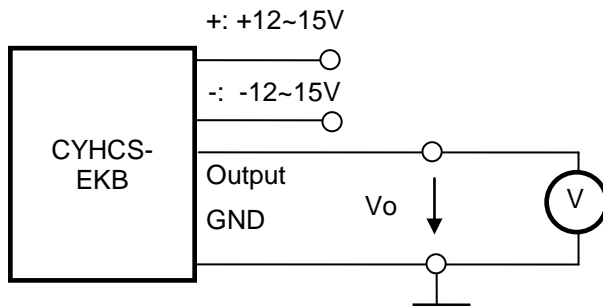

## Notes:

1. Connect the terminals of power source, output respectively and correctly, never make wrong connection.
2. Two potentiometers can be adjusted, only if necessary, by turning slowly to the required accuracy with a small screwdriver.
3. The best accuracy can be achieved when the window is fully filled with bus-bar (current carrying conductor).
4. The in-phase output can be obtained when the direction of current of current carrying conductor is the same as the direction of arrow marked on the transducer