

Open Loop Hall AC/DC Current Sensor CYHCS-K7S



This Hall Effect current sensor is based on open loop principle and can be used for measurement of DC and AC current, pulse currents etc. The output of the transducer reflects the real wave of the current carrying conductor.

Product Characteristics	Applications
<ul style="list-style-type: none"> • Excellent accuracy • Very good linearity • Small size and encapsulated • Less power consumption • Current overload capability 	<ul style="list-style-type: none"> • General Purpose Inverters • AC/DC Variable Speed Drivers • Battery Supplied Applications • Uninterruptible Power Supplies • Switched Mode Power Supplies

Electrical Data/Input

Primary Nominal Current I_r (A)	Primary Current Measuring Range I_p (A) at $V_{cc}=5V$	Primary Conductor \varnothing (mm)	Part number
5	± 10	0.8	CYHCS-K7S-05A
10	± 20	0.8	CYHCS-K7S-10A
15	± 30	0.8	CYHCS-K7S-15A
20	± 40	0.8	CYHCS-K7S-20A
25	± 50	1.4	CYHCS-K7S-25A
30	± 60	1.4	CYHCS-K7S-30A
40	± 80	1.6	CYHCS-K7S-40A
50	± 100	1.6	CYHCS-K7S-50A

Supply Voltage
Current Consumption
RMS Voltage for 2.5kV AC isolation test, 50/60Hz, 1min,
Isolation Resistance at 500V DC

$V_{cc} = 5V \pm 5\%$,
 $I_c < 20mA$
 $V_{is} < 10mA$
 $R_{is} > 500 M\Omega$

Electrical Data/Output

Output Voltage (Analog) at I_r , $T_A=25^\circ C$:
Output Impedance:
Load Resistor:

$V_{out} = 2.5 \pm 1V$
 $R_{out} < 150\Omega$
 $R_L > 10k\Omega$

Accuracy

Accuracy at I_r , $T_A=25^\circ C$ (without offset),
Linearity from 0 to I_r , $T_A=25^\circ C$,
Electric Offset Voltage, $T_A=25^\circ C$,
Magnetic Offset Voltage ($I_r \rightarrow 0$)
Thermal Drift of Offset Voltage,

$X < 1.0\%$
 $E_L < 1.0\% FS$
 $V_{oe} < 40mV$
 $V_{om} < 15mV$
 $V_{ot} < \pm 1mV/^\circ C$

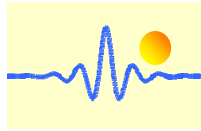

Thermal Drift (-10°C to 50°C),
Response Time at 90% of I_P ($f=1\text{kHz}$)
Frequency Bandwidth (-3dB),

T.C. $< \pm 0.1\% / ^\circ\text{C}$
 $t_r < 1\mu\text{s}$
 $f_b = 50\text{ kHz}$

General Data

Ambient Operating Temperature,
Ambient Storage Temperature,

$T_A = -25^\circ\text{C} \sim +85^\circ\text{C}$
 $T_S = -40^\circ\text{C} \sim +100^\circ\text{C}$

Functional Block Diagram

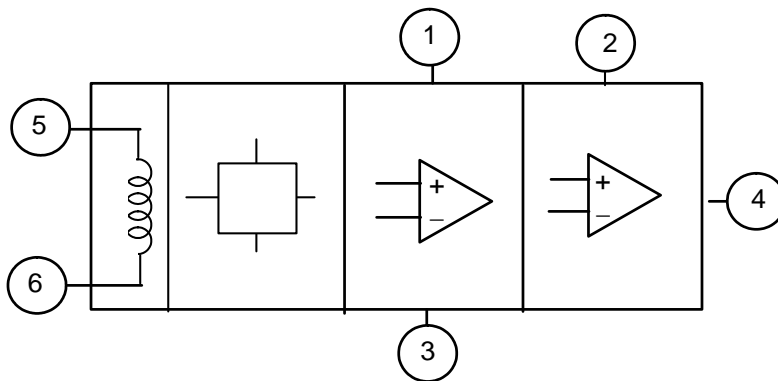

1. V +
2. 0V
3. V_{output}
4. Ground
5. Coil Input +
6. Coil Input -

PIN Definition

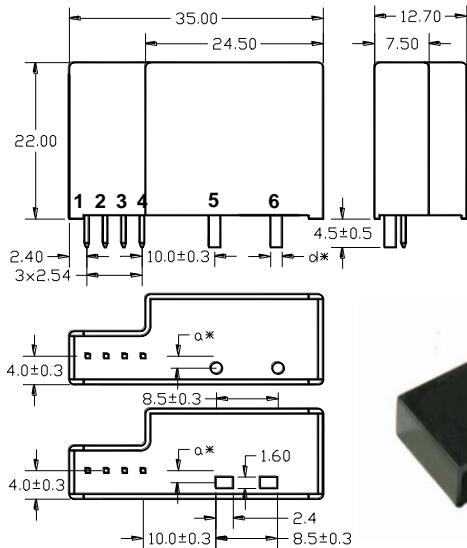

1. V+
2. 0V
3. Output
4. Ground
5. Coil Input +
6. Coil Input -

Primary Conductor Terminal

Part number	a (mm)	d(mm)
CYHCS-K7S-05A	1.3	Ø 0.8
CYHCS-K7S-10A	1.4	Ø 0.8
CYHCS-K7S-15A	1.6	Ø 0.8
CYHCS-K7S-20A	1.6	Ø 0.8
CYHCS-K7S-25A	1.7	Ø 1.4
CYHCS-K7S-30A	1.7	Ø 1.4
CYHCS-K7S-40A	1.7	Ø 1.6
CYHCS-K7S-50A	1.7	Ø 1.6



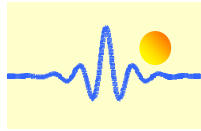

Relation between Input Current and Output Voltage

Take the sensor CYHCS-K7S-30A as sample, the relation between the input current and output voltage is shown in the table 1, Fig.1 and Fig. 2

Table 1. Relation between the input current and output voltage

Input current (A)	-60	-45	-30	-15	0	15	30	45	60
Output voltage (V)	0.5	1.0	1.5	2.0	2.5	3.0	3.5	4.0	4.5

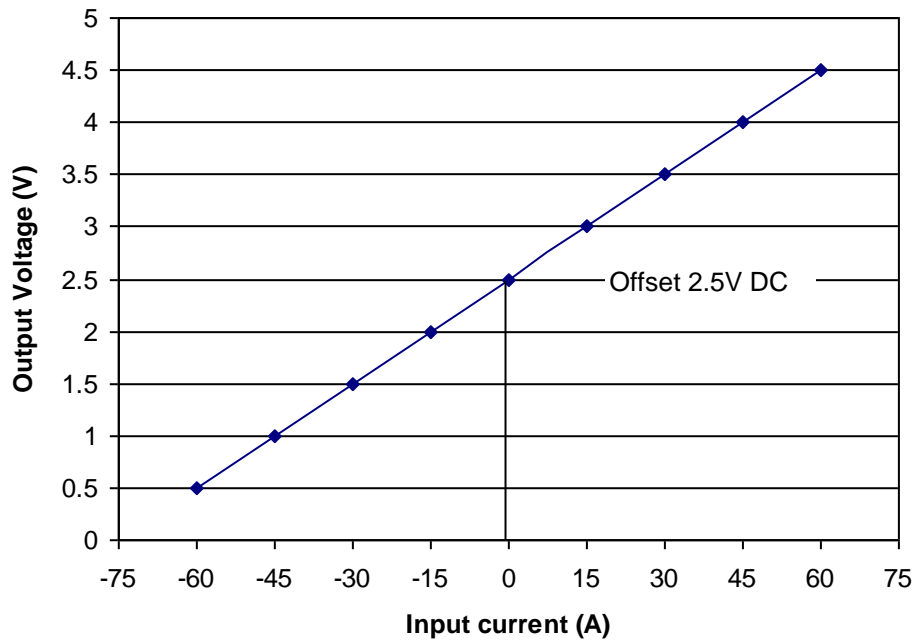

Fig. 1 Relation between the input current (DC) and output voltage (DC)

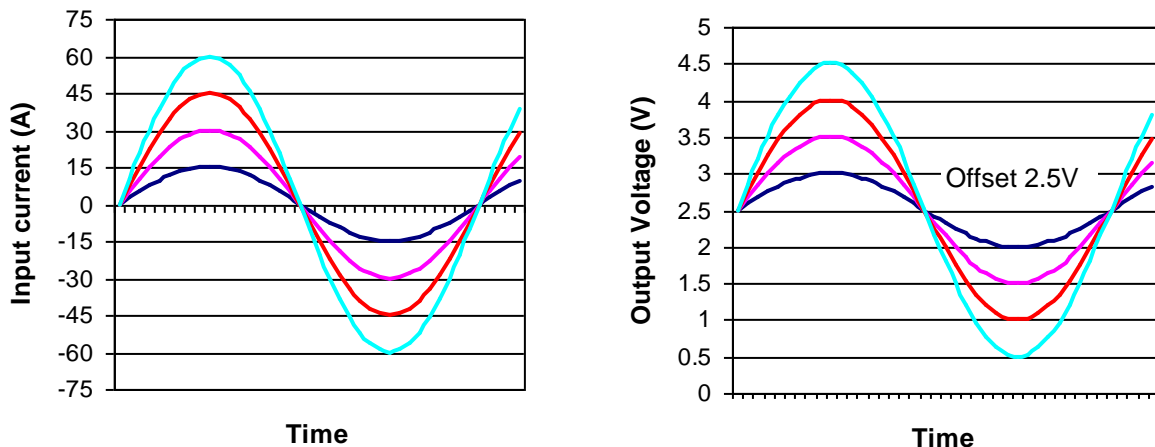

Fig. 2 Relation between the input current (AC) and output voltage (AC)