



Split Core Hall Effect AC/DC Current Sensor CYHCS-WLY

The sensor CYHCS-WLY is a Split Core Hall Effect sensor for the measurement of AC/DC current. The sensor has a galvanic isolation between the high power primary and the secondary electronic circuits with voltage output.

Features and Advantages	Applications
<ul style="list-style-type: none"> AC/DC current measurement Output signal option (0-20mA, 4-20mA, 0-5V, $\pm 5V$, 0-10V) 35mm DIN Rail High isolation between primary and secondary circuits No insertion losses Split Core, easy installation 	<ul style="list-style-type: none"> Battery banks, such as, monitoring load current and charge current, verifying operation Transportation, measuring traction power or auxiliary loads Phase fired controlled heaters Directly connect to PLC Sense motor stalls and short circuits Industrial instrumentation

Specifications

Rated input current (DC current calibration)	50A,80A,100A,150A,200A,300A,400A
Linear measuring range	1.2 times of rated input current
Output signals	$\pm 5VAC/DC$, 0-5VDC, 0-10VDC, 0-20mADC, 4-20mADC
Power supply	+12V DC, +24V DC, $\pm 12V$ DC, $\pm 15V$ DC
Measuring accuracy	$\pm 1.0\%$
Linearity (10% - 100%), 25°C	$\leq \pm 0.5\%$
Zero offset voltage	$\pm 25mV$
Hysteresis error	$\pm 10mV$
Thermal drift of offset voltage	$\leq 400PPM/^\circ C$
Galvanic isolation	6 kV AC, 50Hz, 1min
Isolation resistance	$\geq 100M\Omega$
Response time	$\leq 3\mu s$ for tracing output, $\leq 150ms$ DC output
Frequency range	DC ~ 10kHz
di/dt following accuracy	50A/ μs
Overload capacity	20 times
Current consumption	$\leq 50mA$
Output load	Voltage output : $\geq 2k\Omega$, Current output: $\leq 250\Omega$
Mounting	35mm DIN Rail
Case style and Window size	WLY with aperture $\varnothing 25mm$
Operating temperature	-25°C ~ +70°C
Storage temperature	-45°C ~ + 85°C
Relative humidity	$\leq 90\%$
Mean Time Between Failures (MTBF)	$\geq 100k$ hours

Definition of Part number:

CYHCS	-	WLY	-	m	-	x	n
-------	---	-----	---	---	---	---	---

(1) (2) (3) (4) (5)

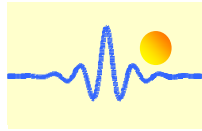

(1)	(2)	(3)	(4)	(5)
Series name	Case style	Rated Input current (m)	Output signal	Power supply
CYHCS	WLY	m = 50A, 80A, 100A, 150A, 200A, 250A, 300A, 400A	x=1: tracing voltage $\pm 5V$ AC/DC x=3: 0-5V DC x=4: 0-20mA DC x=5: 4-20mA DC x=8: 0-10V DC	n=2: +12V DC n=4: +24V DC n=5: $\pm 12V$ DC n=6: $\pm 15V$ DC

Example 1: CYHCS-WLY-100A -15, Hall Effect AC/DC Current sensor with
Output signal: tracing voltage $\pm 5V$ AC/DC
Power supply: $\pm 12V$ DC
Rated input current: 100A AC/DC

Example 2: CYHCS-WLY-100A -14, Hall Effect AC/DC Current sensor with
Output signal: tracing voltage $\pm 5V$ AC/DC
Power supply: +24V DC
Rated input current: 100A AC/DC

Example 3: CYHCS-WLY-100A -54, Hall Effect AC/DC Current sensor with
Output signal: 4-20mA DC
Power supply: +24V DC
Rated input current: 100A AC/DC

DIMENSIONS (mm)

LxWxH: 74mm x 83mm x 25mm
Window Size: 25mm
35mm DIN Rail

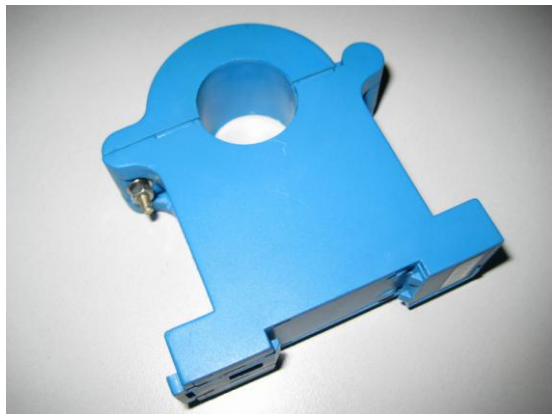

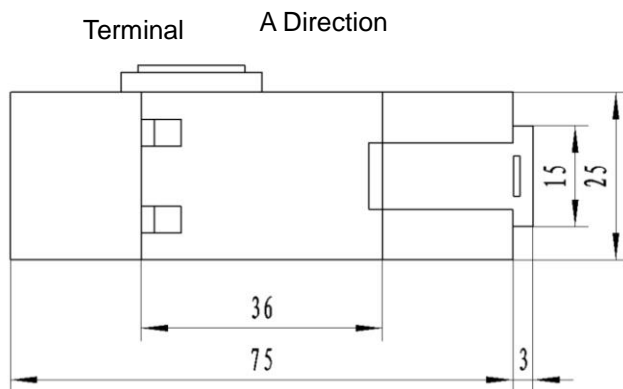
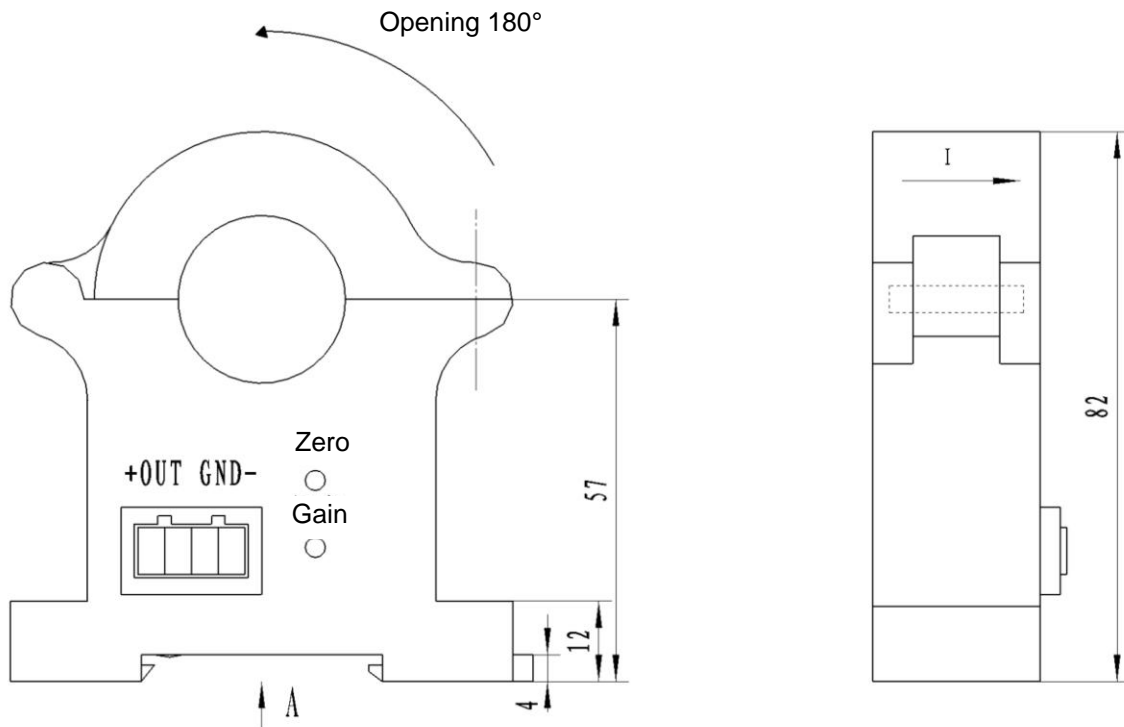

Pin Arrangement:

- +: V+
- : V- (or NC)
- OUT: Output
- GND: Ground





CONNECTIONS

The current carrying cable must pass through the window. The phase of output is the same as that of the current passing the window in the direction of the arrow indicated on the case.

a) Wiring of Sensors Using Double Power Supplies

Voltage Output

- 1(+): +15V/+12V Power Supply
- 2(OUT): Output
- 3(GND): Ground
- 4(-): -15V/-12V Power Supply

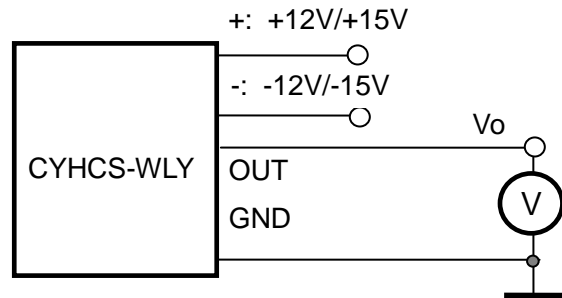

Relation between Input and Output:

Sensor CYHCS-WLY-100A-15	
Input current (A)	Output voltage (V)
-100	-5
-75	-3.75
-50	-2.5
-25	-1.25
0	0
25	1.25
50	2.5
75	3.75
100	5

Current Output

- 1(+): +12V/+15V Power Supply
- 2(OUT): Output
- 3(GND): Ground
- 4(-): -12V/-15V Power Supply

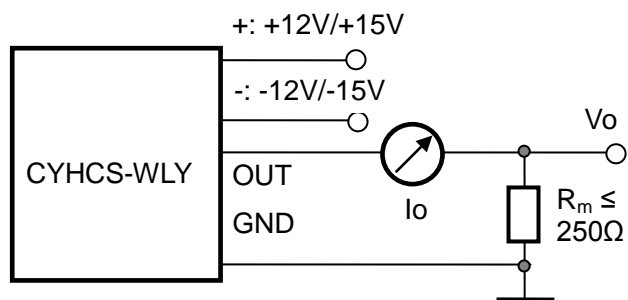

Relation between Input and Output (for $R_m=250 \Omega$):

Sensor CYHCS-WLY-100A-45		
Input current (A, RMS/DC)	Output current I_o (mA, DC)	Output voltage V_o (V, DC)
0	0	0
25	5	1.25
50	10	2.5
75	15	3.75
100	20	5

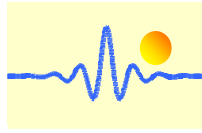

B) Wiring of Sensors Using Single Power Supply

Voltage Output

1(+): +12V, +24V
2(OUT): Output
3(GND): Ground
4(-): NC

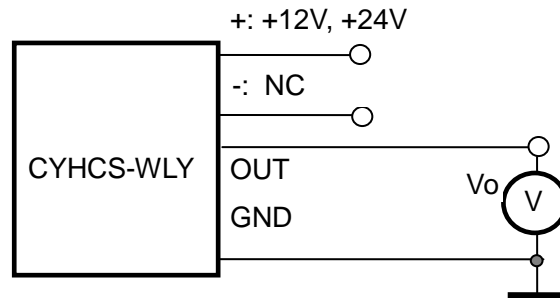

Relation between Input and Output:

Sensor CYHCS-WLY-100A-14	
Input current (A)	Output voltage (V)
-100	-5
-50	-2.5
0	0
50	2.5
100	5

Current Output

1(+): +12V, +24V
2(OUT): Output
3(GND): Ground
4(-): NC

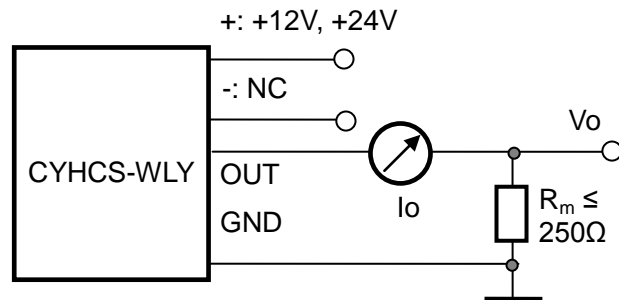

Relation between Input and Output (for $R_m=250 \Omega$):

Sensor CYHCS-WLY-100A-54		
Input current (A, RMS/DC)	Output current I_o (mA, DC)	Output voltage V_o (V, DC)
0	4	1
25	8	2
50	12	3
75	16	4
100	20	5

Notes:

1. Connect the terminals of power source, outputs respectively and correctly, never make wrong connection.
2. Two potentiometers can be adjusted, only if necessary, by turning slowly to the required accuracy with a small screwdriver.
3. The best accuracy can be achieved when the window is fully filled with bus-bar (current carrying conductor).
4. The in-phase output can be obtained when the direction of current of current carrying conductor is the same as the direction of arrow marked on the transducer case.