



## Hall Effect Voltage Sensor CYHVS025A

CYHVS025A is a Hall Effect Voltage sensor, which is based on closed loop and magnetic compensation principle. This sensor can be used for measuring DC and AC voltage with different wave forms. It has high electric isolation.

### Features

- High electrical isolation
- High reliability
- Good overload capability
- Small sizes
- Insulated plastic case recognized according to UL94-V0
- Very good property-price ratio

### Applications

- Switched Mode Power Supplies
- Uninterruptible power supplies (UPS)
- Overvoltage protection
- Feedback of control systems
- Electric power network monitoring
- AC frequency conversion servo-motors
- Various power supplies
- Power supply for welding applications

### Electrical Parameters

Parameters	Values			Unit
Rated input current ( $I_N$ )	$\pm 10$			mA
Measuring range ( $I_P$ )	0~ $\pm 14$			mA
Rated measuring voltage	500			V
Max. measuring voltage	1000			V
Measuring resistance ( $R_M$ )		$R_{Mmin}$	$R_{Mmax}$	
	@ $\pm 10$ mA	100	350	$\Omega$
	@ $\pm 14$ mA	100	190	$\Omega$
Rated secondary current ( $I_S$ )	$\pm 25$			mA
Power supply ( $V_C$ )	$\pm 15$ ( $\pm 5\%$ )			V
Turns ratio (N)	2500 : 1000			
Current consumption ( $I_C$ )	15+ $I_S$			mA
Isolation voltage ( $V_d$ )	2.5kV/50Hz/1min			
Measuring accuracy ( $X_G$ )	$\pm 0.5\%$ FS (Full Scale)			
Linearity ( $\epsilon_L$ )	<0.2% FS			
Offset current ( $I_o$ )	$\pm 0.1$			mA
Thermal drift of offset current $I_o$ ( -40°C~+85°C )	$\pm 0.5$			mA
Response time ( $t_r$ )	<40			$\mu s$
Ambient operating temperature ( $T_A$ )	- 40°C ~ +85°C			
Ambient storage temperature ( $T_S$ )	-40°C ~ +125°C			
Primary coil resistance ( $R_p$ )	@ $T_a=25^\circ C$ , 200			$\Omega$
Secondary coil resistance ( $R_s$ )	@ $T_a=25^\circ C$ , 110			$\Omega$

Polarity: output current  $I_S$  is positive when input current  $I_P$  is applied on the "+" terminal

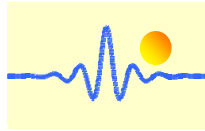

## Case Style and Connection

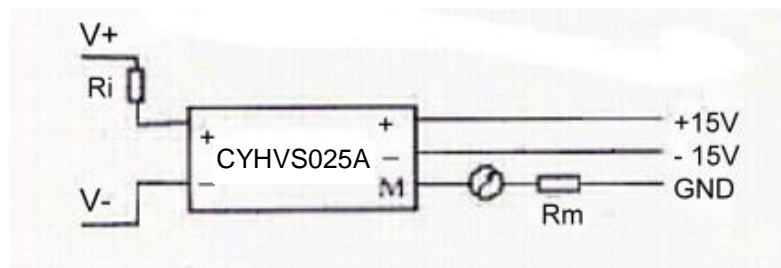
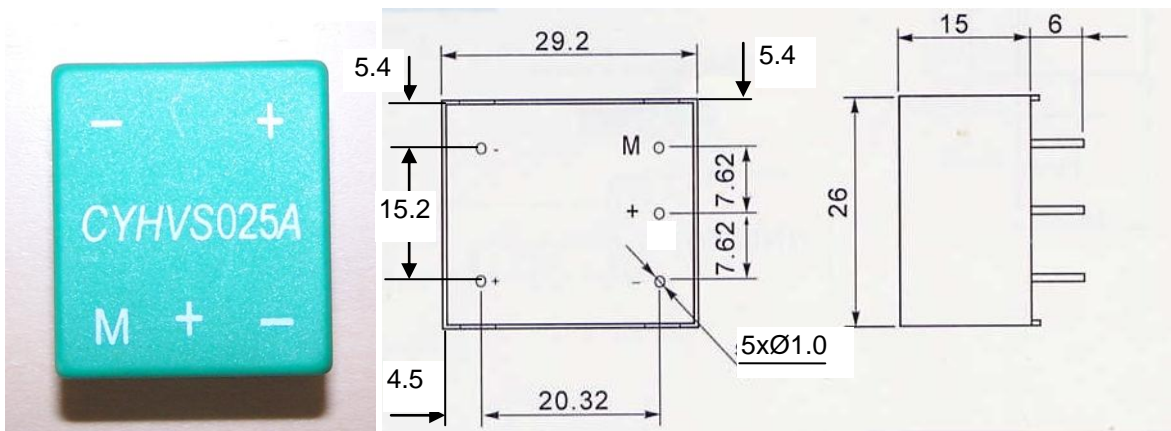

## Measuring Principle

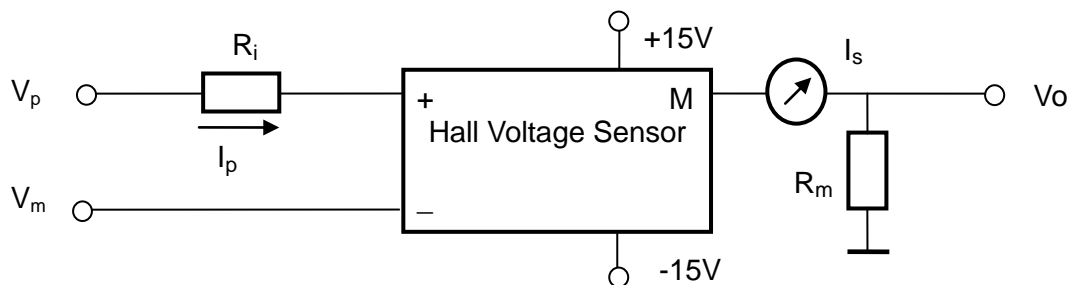

A magnetic field is generated by current  $I_p$  when a voltage ( $V_p - V_m$ ) is applied on the input terminals of the sensor through the primary resistor  $R_i$ . This magnetic field is compensated with the reverse magnetic field caused by the current  $I_s$  in the secondary coil. The field compensation effect can be detected with a Hall Effect element. One obtains the following equation when the magnetic flux is zero:

$$N_p I_p = N_s I_s$$

where  $I_p$ : primary current;  $I_s$ : secondary current,  
 $N_p$ : primary turns,  $N_s$ : secondary turns.

The secondary current  $I_s$  is considered as output current of the sensor. Therefore the voltage ( $V_p - V_m$ ) can be measured in this way under using the measuring resistor  $R_m$ .

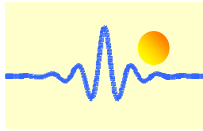

## Application Note

### 1) Determination of Primary Resistor $R_i$

The primary resistor  $R_i$  should be selected to enable the rated input current to be equal to 5mA in order to obtain an optimal measuring accuracy.

For instance, the resistor  $R_i$  is 25k $\Omega$  for a rated input voltage of 250V. Here is recommended resistor in dependence of the measuring voltage:

Rated input voltage (V)	Resistor $R_i$ (k $\Omega$ )
10	1
50	5
100	10
200	20
300	30
400	40
500	50

### 2) Measuring Range

The sensors are suitable for measuring a voltage 0 ~  $\pm 500V$ . The primary resistor should be considered when selecting the measuring range in order to keep the temperature heating to a possible low level and to guarantee the high electric isolation property.