



CYS1362 High Sensitive Omnipolar TMR Switch IC

The CY1362 is a $0.2\mu\text{A}$ ultra-low power magnetic switch sensor. It is a digital omnipolar magnetic switch that integrates TMR and CMOS technology in order to provide a magnetically triggered digital switch with high sensitivity, high speed, and ultra-low power consumption. It integrates a push-pull half-bridge TMR magnetic sensor and CMOS signal processing circuitry within the same package.



Designed for use in applications that are both power-critical and performance-demanding, this device includes an on-chip TMR voltage generator for precise magnetic sensing, TMR voltage amplifier and comparator, a Schmitt trigger to provide switching hysteresis for noise rejection, and CMOS push-pull output. An internal band gap regulator is used to provide temperature compensated supply voltage for internal circuits, and it allows a wide range of operating supply voltages. The CYS1362 features ultra-low power consumption at 200nA with a fast internal switching frequency at 50Hz . Other important features include accurate switching points, excellent thermal stability, and a wide range of supply voltages. It is available in two packaging form factors: SOT23-3 or TO-92S.

Features

- Operation with North or South Pole
- Low power consumption ($<0.2\mu\text{A}$)
- High tolerance to external magnetic field interference
- Low switch points for high sensitivity
- Excellent thermal stability

Typical Applications

- Water, gas and heat meters
- Proximity Switches
- DC Brushless Motor
- DC Brushless Fan
- Position and speed sensing

Functional Block Diagram

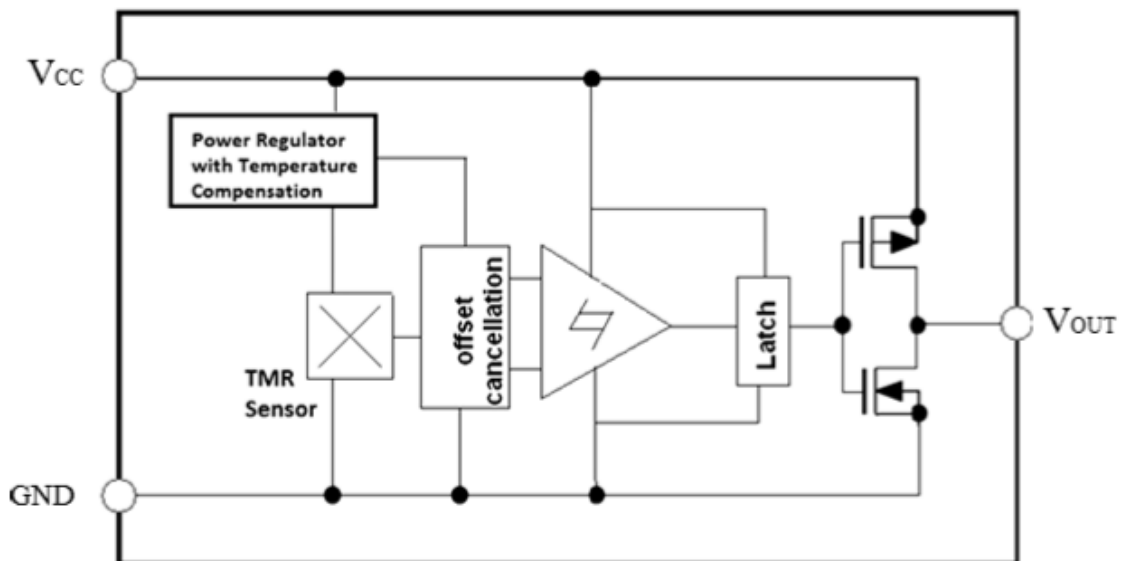



Absolute Maximum Ratings

Parameter	Symbol	Limit	Unit
Supply Voltage	V_{CC}	7	V
Reverse Supply Voltage	V_{RCC}	0.3	V
Output Current	$I_{OUTSINK}$	9	mA
Magnetic Flux Density	B	4000	G
ESD level (HBM)	V_{ESD}	2	kV
Operating Ambient Temperature	T_A	-40 ~ 125	°C
Storage Temperature	T_{stg}	-50 ~ 150	°C

Electrical Characteristics ($V_{CC}=3.0V$, $T_A=25^\circ C$)

Parameter	Symbol	Conditions	Min	Typ.	Max	Unit
Supply Voltage	V_{CC}	Operating	1.8	3.0	5.5	V
Output High Voltage	V_{OH}		$V_{CC}-0.3$		V_{CC}	V
Output Low Voltage	V_{OL}		0		0.2	V
Supply Current	I_{CC}	Output open		0.2		μA
Response Frequency	F			50		Hz

Note: a 100nF capacitor is connected between V_{CC} and GND during all tests in the above table.

Magnetic Characteristics ($V_{CC} = 3.0V$, $T_A = 25^\circ C$)

Parameters	Symbol	Min	Typ.	Max	Unit
Operate Point	B_{OPS}		17		G
	B_{OPN}		-17		G
Release Point	B_{RPS}		12		G
	B_{RPN}		-12		G
Hysteresis	B_H		5		G

Note: a 100nF capacitor is connected between V_{CC} and GND during all tests in the above table.

Voltage and Temperature Characteristics

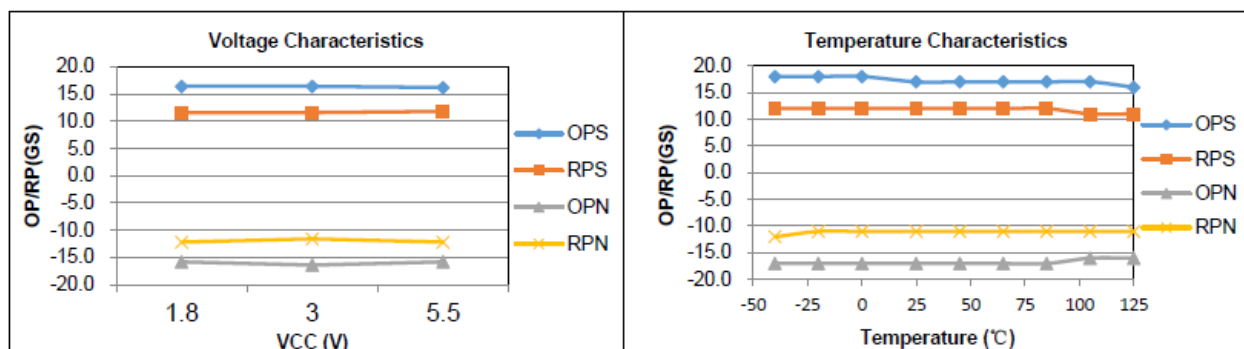



Output Behavior vs. Magnetic Pole

Parameter	Test Conditions	Output
South Pole	$B > B_{OPS}$	Low (On)
	$0 < B < B_{RPS}$	High (Off)
North Pole	$B < B_{OPN}$	Low (Off)
	$0 > B > B_{RPN}$	High (On)

Note: when power is turned on under zero magnetic field, the output is "High".

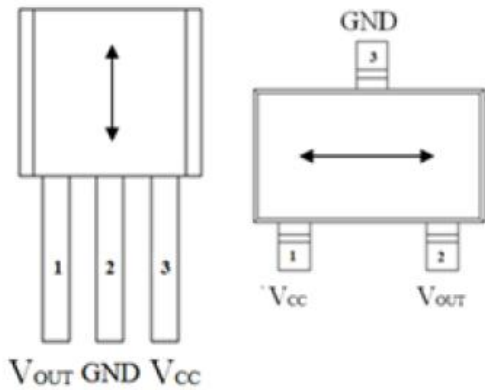

Sensing direction of magnetic field

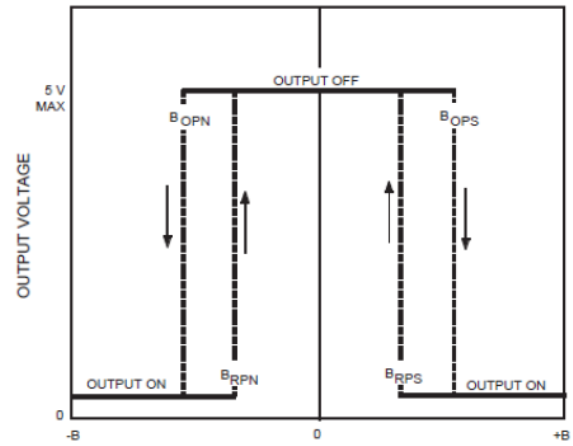

Magnetic Flux

Pin Configuration

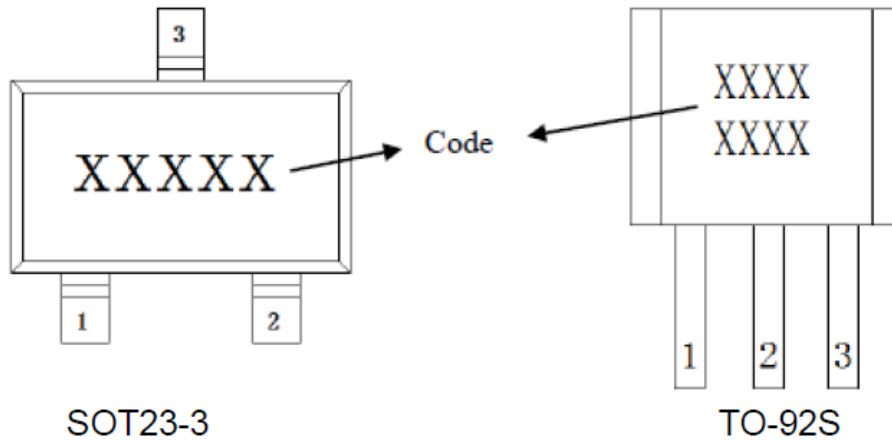

Pin Name	Pin No.		Pin Function
	TO-92S	SOT23-3	
VCC	3	1	Supply Voltage
GND	2	3	Ground
VOUT	1	2	Output



Application Information

The output of the CYS1362 switches low (turns on) when a magnetic field parallel to the TMR sensor exceeds the operate point threshold, B_{OP} . When the magnetic field is reduced below the release point, B_{RP} , the device output goes high (turns off). The difference between magnetic operate point and release point is the hysteresis B_H of the device.

It is strongly recommended that an external bypass capacitor be connected in close proximity to the device between the supply and ground to reduce noise. The typical value of the external capacitor is $0.1\mu\text{F}$.

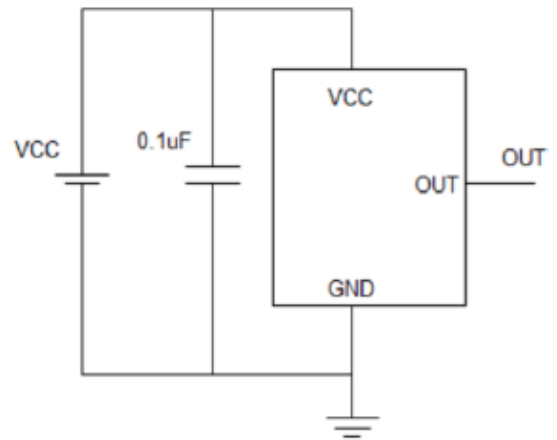

TMR Sensor Position (unit: mm)

SOT23-3

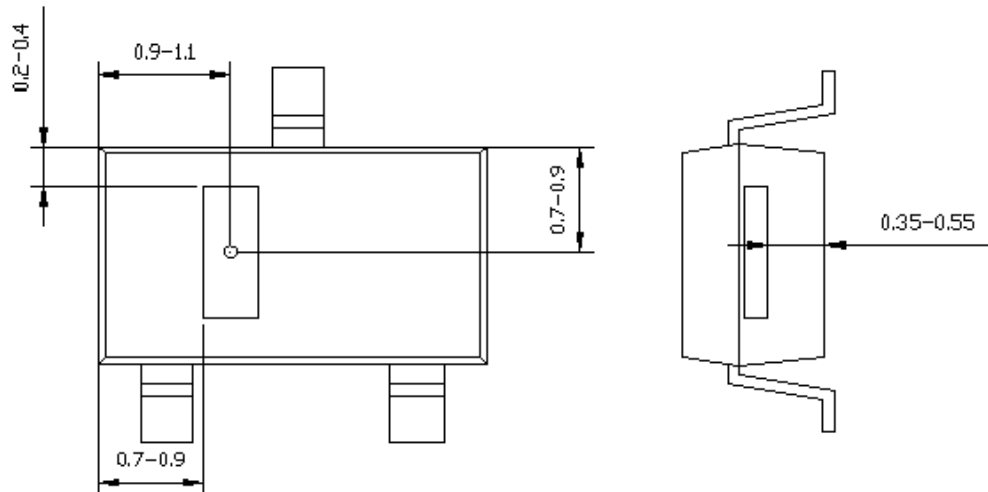

TO-92S

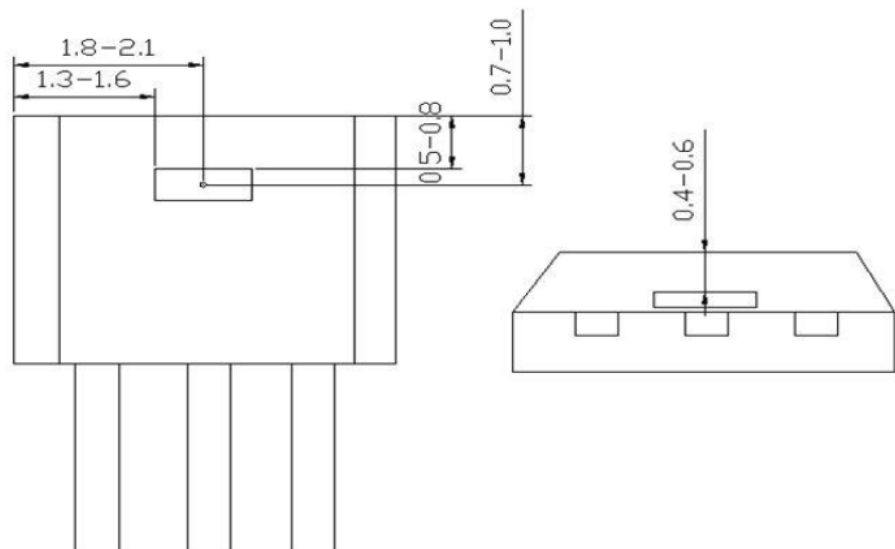

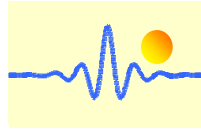

Package Information

SOT23-3 Package Drawing

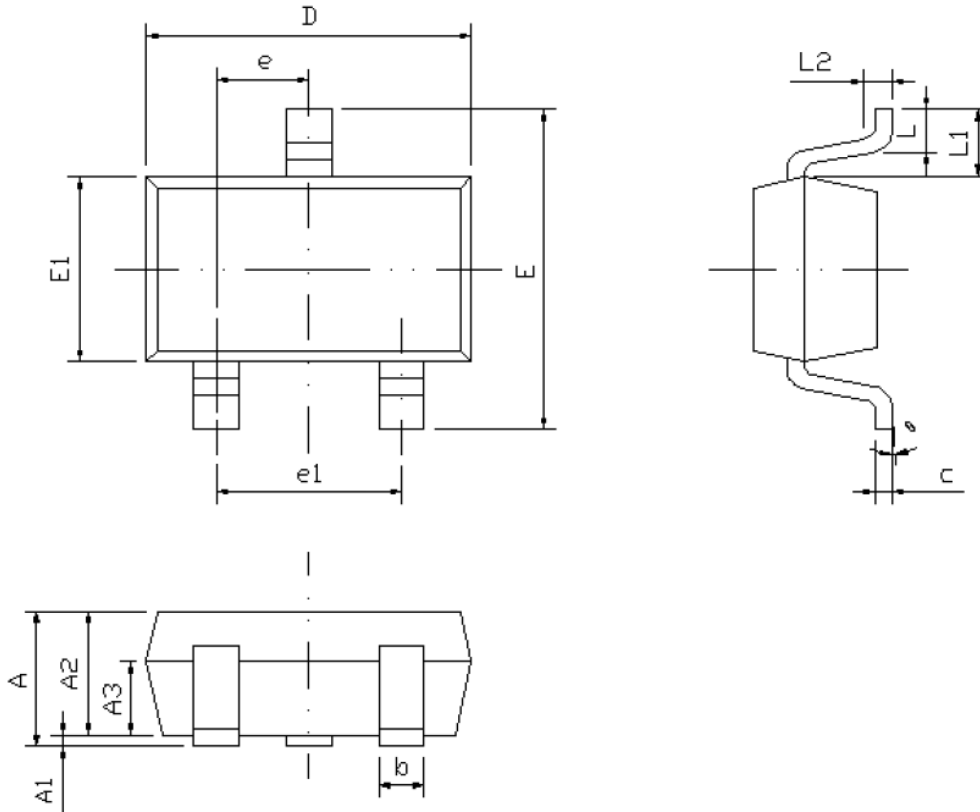

Symbol	Dimensions in mm			Dimensions in inches		
	min	nom	max	min	nom	max
A	-	-	1.45	-	-	0.057
A1	0.00	-	0.15	0.000	-	0.006
A2	0.90	1.10	1.30	0.035	0.043	0.051
A3	0.60	0.65	0.70	0.024	0.026	0.028
b	0.39	-	0.49	0.015	-	0.019
c	0.12	-	0.19	0.005	-	0.007
D	2.85	2.95	3.05	0.112	0.116	0.120
E	2.60	2.80	3.00	0.102	0.110	0.118
E1	1.55	1.65	1.75	0.061	0.065	0.069
e	0.85	0.95	1.05	0.033	0.037	0.041
e1	1.80	1.90	2.00	0.071	0.075	0.079
L	0.35	0.45	0.60	0.014	0.018	0.024
L1	0.59REF			0.023REF		
L2	0.25BSC			0.010BSC		
θ	0°	-	8°	0°	-	8°

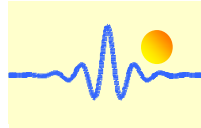

TO-92S Package Drawing

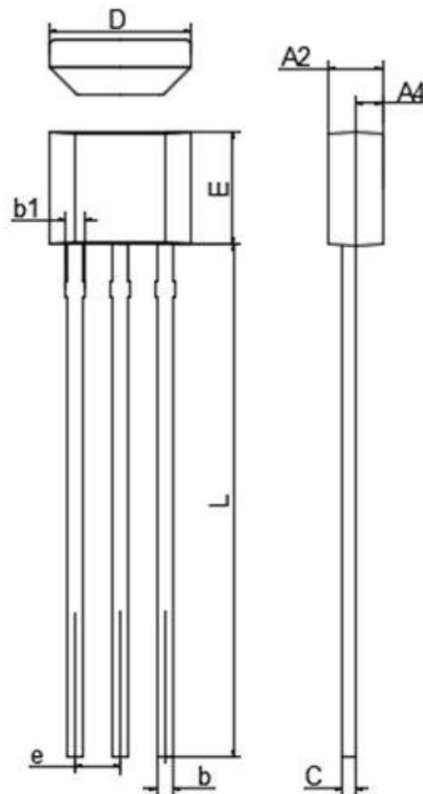

Symbol	Dimensions in mm			Dimensions in inches		
	min	nom	max	min	nom	max
A2	1.40	1.50	1.60	0.055	0.059	0.063
A4	0.75 TYP			0.030 TYP		
b	0.34	0.39	0.42	0.013	0.015	0.017
b1	0.40	0.46	0.50	0.016	0.018	0.020
C	0.37	0.40	0.42	0.015	0.016	0.017
D	3.90	4.10	4.20	0.154	0.161	0.165
E	2.90	3.05	3.30	0.114	0.120	0.130
e	1.27 TYP			0.050 TYP		
L	14.0	14.5	15.0	0.551	0.571	0.590

Part number

Part number	Response Frequency	Operating Temperature	Package
CYS1362S	1000Hz	-40°C ~ 125°C	SOT23-3
CYS1362T	1000Hz	-40°C ~ 125°C	TO-92S