

3-Phase 3-Wire AC Voltage Sensor CYVS13-xnU0

The **CYVS13-xnU0** AC Voltage Sensor/Transducer works according to electromagnetic induction and is designed for applications to measurement and monitoring of 3-Phase 3-Wire AC voltage. The output signals (DC voltage or current) of this transducer are proportional to the average effective value (RMS) of input AC voltages. They are suitable for general applications such as fixed frequency voltage supplies and sinusoid voltages etc.

Specifications

Rated input voltage (U _x)	10V-500V AC
Linear measuring range	0 - 1.2 times of rated input voltage
Overload capacity	2 times of rated input voltage
Frequency of Input voltage	Typ. 50Hz, 60Hz, max. 5kHz
Input resistance	$R_i=0.667U_x \times 1k\Omega/V$, U_x : input voltage
Output signals DC	0-5V, 0-10V, 0-20mA, 4-20mA DC
Measuring accuracy	0.5%
Load capacity	voltage output: 5mA; current output: 6V
Response time	≤300ms
Thermal drift	voltage output : 250ppm/°C; current output: 350ppm/°C
Power supply	+12VDC, +24VDC
Static current	Voltage output: 8mA; 0-20mA output: 12mA; 4-20mA output: 35mA
Isolation	Isolation between input and output, power supply at the output
Isolation withstanding voltage	2.5 kV DC, 1min
Operating temperature	-10°C ~ +60°C
Storage temperature	-25°C ~ + 70°C
Relative humidity	10% ~ 90%
Protection of Case	IP20
Material of Case	ABS (according to UL94V-0)
Mounting	DIN Rail
Case Style	U0 without aperture
MTBF	50000h
Unit weight	90g

Definition of Part number:

CYVS13	-	x	n	U0	-	0.5	-	m
(1)		(2)	(3)	(4)		(5)		(6)

(1)	(2)	(3)	(4)	(5)	(6)
Series name	Output signal	Power supply	Case style	Accuracy class	Input Voltage range (m)
CYVS13	x=1: 0-5VAC x=3: 0-5V DC x=4: 0-20mA DC x=5: 4-20mA DC	n=2: +12V DC n=4: +24V DC	U0	0.5%	m=10V-500V AC
	x=8: 0-10V DC	n=4: +24V DC			

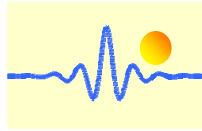

Example 1: CYVS13-32U0-0.2-100V, 3-phase 3 wire AC voltage sensor with
Output signal: 0-5V DC
Power supply: +12V DC
Rated input voltage: 0-100V AC

Example 2: CYVS13-54U0-0.5-100V, 3-phase 3 wire AC voltage sensor with
Output signal: 4-20mA DC
Power supply: +24V DC
Rated input voltage: 0 -100V AC

DIMENSIONS (mm)

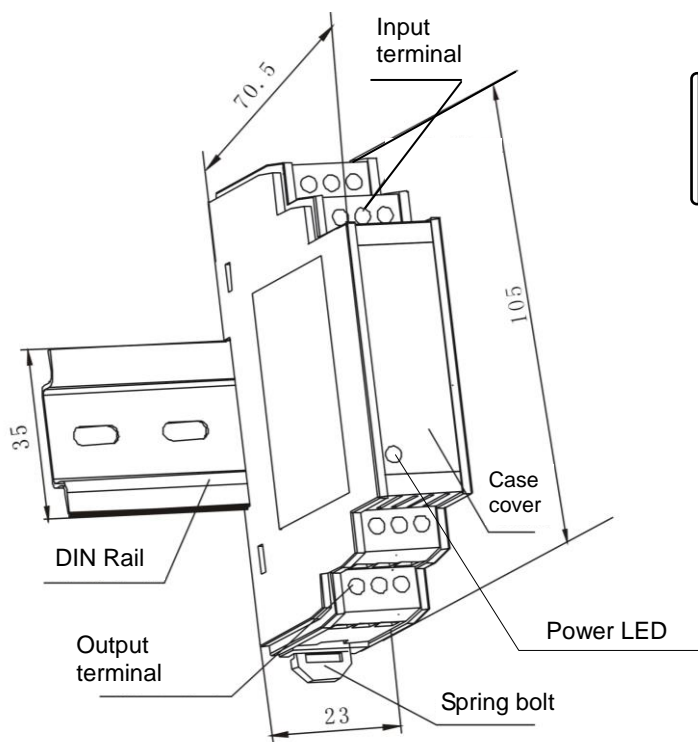

View of A Direction

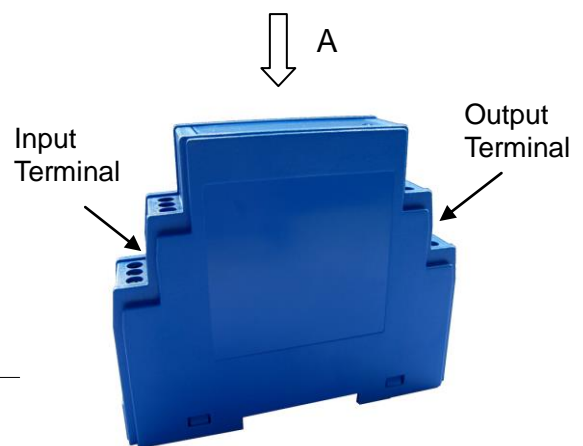
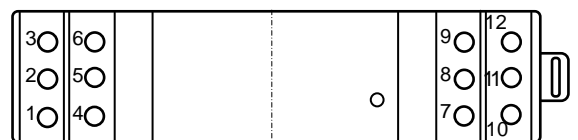

Dimensions: 105mm x 23mm x 70.5mm

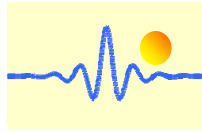

CONNECTIONS

Wiring of Terminals for voltage output:

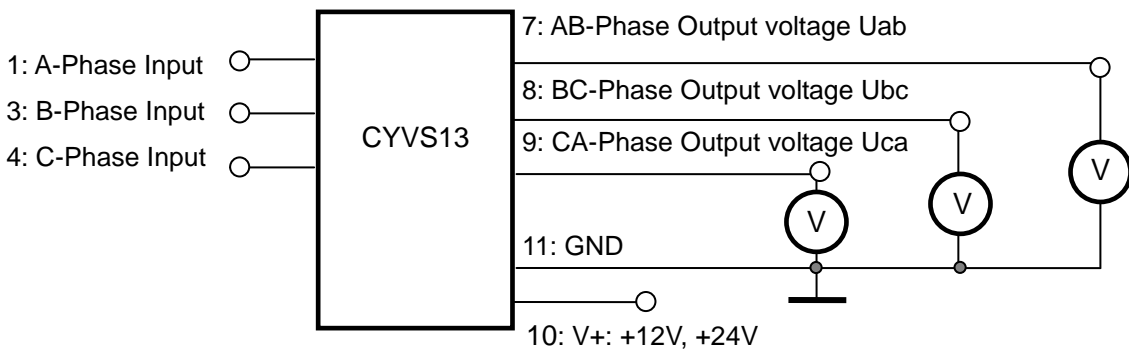
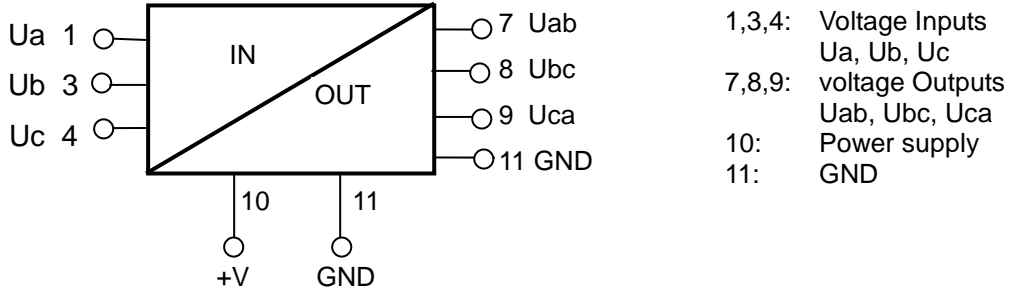

Wiring of Terminals for Current Output:

