



### 3-Phase 4-Wire AC Voltage Sensor CYVS14-xnSK1

The **CYVS14-xnSK1** AC Voltage Sensor/Transducer works according electro-magnetic induction and is designed for applications to measurement and monitoring of 3-Phase 4-Wire AC voltage. The output signals (DC voltage or current) of this transducer are proportional to the average effective value (RMS) of input AC voltages. They are suitable for general applications such as fixed frequency voltage supplies and sinusoid voltages etc.

#### Specifications

Rated input voltage range	50V, 75V, 100V, 200V, 250V, 300V, 380V, 400V, 500V
Output signal	0-5VDC, 0-20 mA, 4-20 mA, 0-10V DC
Output load	≥2kΩ for voltage output, ≤250Ω for current output
Power supply	110V, 220V DC/AC
Measuring accuracy	0.5%
Isolation	between input, output and power supply
Load resistance	≥2kΩ for voltage output, ≤250Ω for current output
Isolation withstanding voltage	2.5 kV DC, 1min, leakage current 1mA
Operating temperature	-10°C ~ +60°C
Storage temperature	-25°C ~ + 70°C
Relative humidity	10% ~ 90%
Response time	≤250ms
Overload capacity	2 times
Quiescent power consumption	400mW – 500mW
Mounting	Din rail
Case style	SK1 without aperture

#### Definition of Part Number:

CYVS14	-	x	n	SK1	-	0.5	-	m
(1)		(2)	(3)	(4)		(5)		(6)

(1)	(2)	(3)	(4)	(5)	(6)
Series name	Output signal	Power supply	Case style	Accuracy class	Input voltage range (m)
CYVS14	x=3: 0-5V DC x=4: 0-20mA DC x=5: 4-20mA DC x=8: 0-10V DC	n=8: 110V DC/AC n=9: 220V DC/AC	SK1	0.5%	50V, 75V, 100V, 200V, 250V, 300V, 380V, 400V, 500V

**Typical example:** CYVS14-38SK1-0.5-380V, 3-Phase 4-Wire AC voltage sensor with  
Output signal: 0-5V DC  
Power supply: 110 DC/AC  
Rated input voltage: 380V AC/RMS



**DIMENSIONS (mm)**

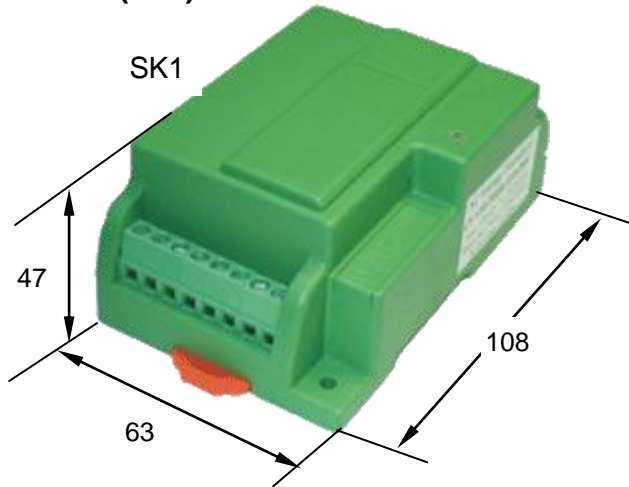

Dimensions:  
47mm x 108mm x 63mm

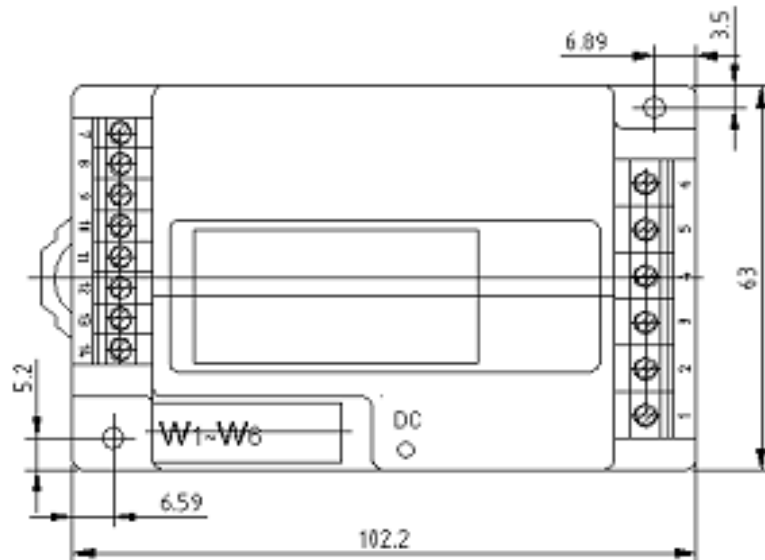

**CONNECTIONS**

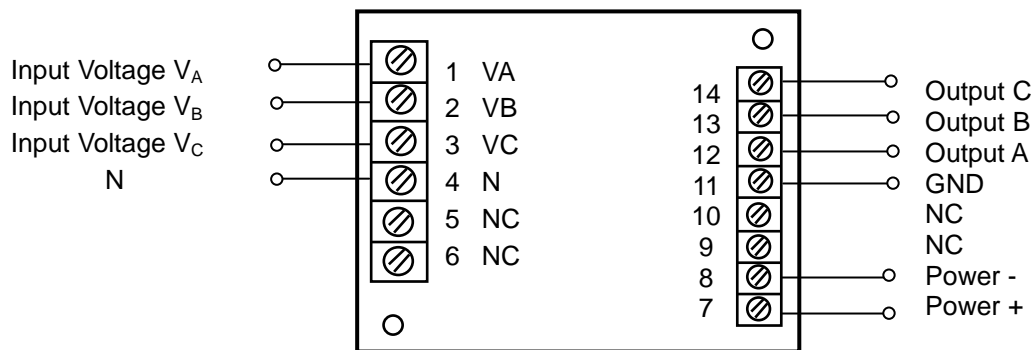

3-Phase 4-Wire AC voltage



### Wiring of Terminals for voltage output:

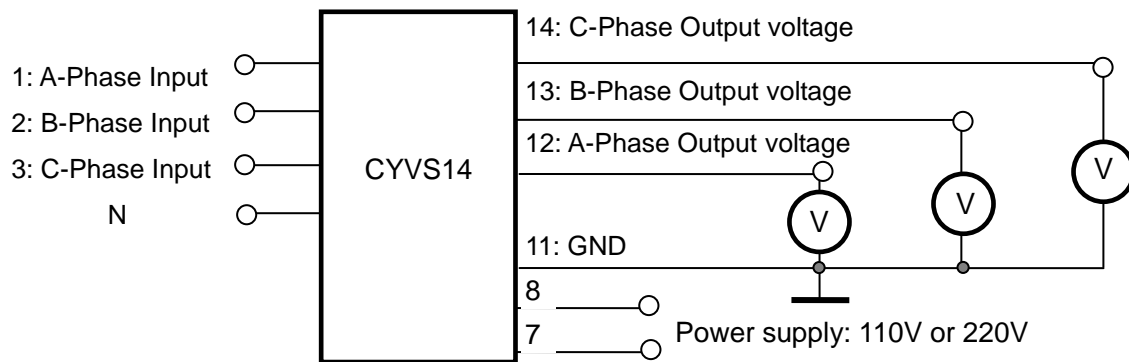

7, 8: Power Supply    11: GND    12, 13, 14: Voltage Output

### Wiring of Terminals for Current Output:

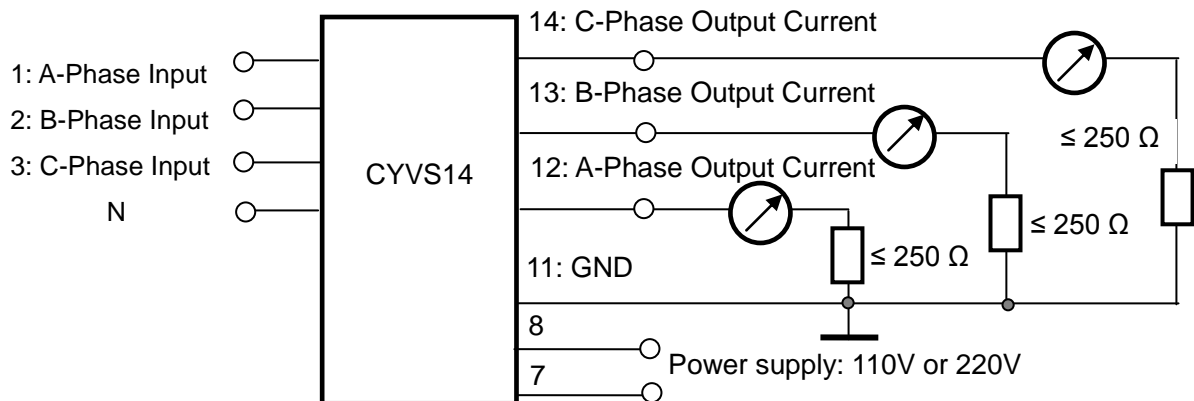

7, 8: Power Supply    11: GND    12, 13, 14: Current Output

### Application:

- Harmonic voltages
- Chopped waveform drivers
- Quickly varying voltage supplies
- Phase fired controlled devices

### Notice:

1. There is no polarity requirement for the input current connection.
2. The output signal and the power source are common grounded at terminal 11.
3. The output at terminal 12 corresponds to the phase voltage  $V_A$ , the output at terminal 13 is phase voltage  $V_B$ , and the output at terminal 14 presents phase voltage  $V_C$