

## DC Voltage Sensor CYVT02-xnS2

The **CYVT02-xnS2** DC voltage sensor/transducer works according Electromagnetic Induction and is designed for applications to measurement and monitoring of DC voltage. The output signal (DC voltage or current) of this transducer is proportional to the input DC voltage. They are suitable for measurements and long time monitoring of DC voltages and can applied to power supply management, DC motor drivers, battery chargers and systems etc.

### Specifications

Rated input voltage range	10mV, 50mV, 75mV, 1V, 5V, 10V, 50V, 75V, 100V, 200V, 500V, 1000V
Output signal	0-5VDC, 0-20 mA, 4-20 mA, 0-10V DC, frequency OC
Power supply	+12V, +15V, +24V DC
Measuring accuracy	0.5%
Isolation	between input, output and power supply
Input resistance	>1MΩ
Load resistance	≥2kΩ for voltage output, ≤250Ω for current output
Isolation withstanding voltage	2.5 kV DC, 1min, leakage current 1mA
Operating temperature	-10°C ~ +60°C
Storage temperature	-25°C ~ + 70°C
Relative humidity	10% ~ 90%
Response time	≤400ms
Overload capacity	2 times
Quiescent power consumption	200mW – 300mW
Mounting	Din rail
Case style	S2 without aperture

### Definition of Part number:

CYVT02	-	x	n	S2	-	0.5	-	M
(1)		(2)	(3)	(4)		(5)		(6)

(1)	(2)	(3)	(4)	(5)	(6)
Series name	Output signal	Power supply	Case style	Accuracy class	Input voltage range (M=U/B+m)
CYVT02	<b>x=3:</b> 0-5V DC <b>x=4:</b> 0-20mA DC <b>x=5:</b> 4-20mA DC <b>x=8:</b> 0-10V DC <b>x=F:</b> Frequency OC**	<b>n=2:</b> +12V DC <b>n=3:</b> +15V DC <b>n=4:</b> +24V DC	S2	0.5%	m = 10mV, 50mV, 75mV, 1V, 5V, 10V, 50V, 75V, 100V, 200V, 500V, 1000V

\*\* Frequency range: 10kHz, accuracy: 0.5%, response time is longer than those given in the table above  
**U:** uni-directional input voltage; **B:** bi-directional input voltage

### Output Signal of Custom Made Sensors:

**x=1:** tracing voltage 5V, **x=2:** tracing current 20mA

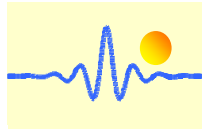

**Example 1:** CYVT02-32S2-0.5-U1000V, DC Voltage sensor with  
Output signal: 0-5V DC  
Power supply: +12V DC  
Rated input voltage: 0-1000V DC (uni-directional)

**Example 2:** CYVT02-54S2-0.5-B1000V, DC Voltage sensor with  
Output signal: 4-20mA DC  
Power supply: +24V DC  
Rated input voltage: -1000V ~ +1000V DC (bi-directional)

**DIMENSIONS (mm)**

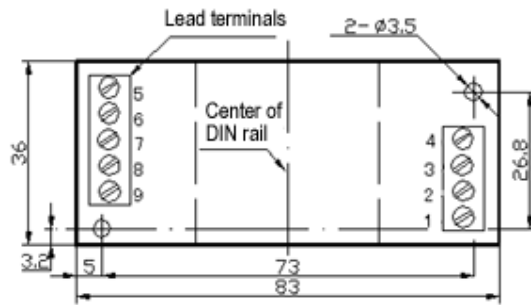
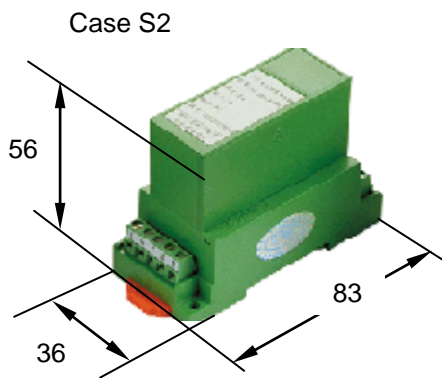

Dimensions: 56mm x 83mm x 36mm

**CONNECTIONS**

**Wiring of Terminals for voltage output:**

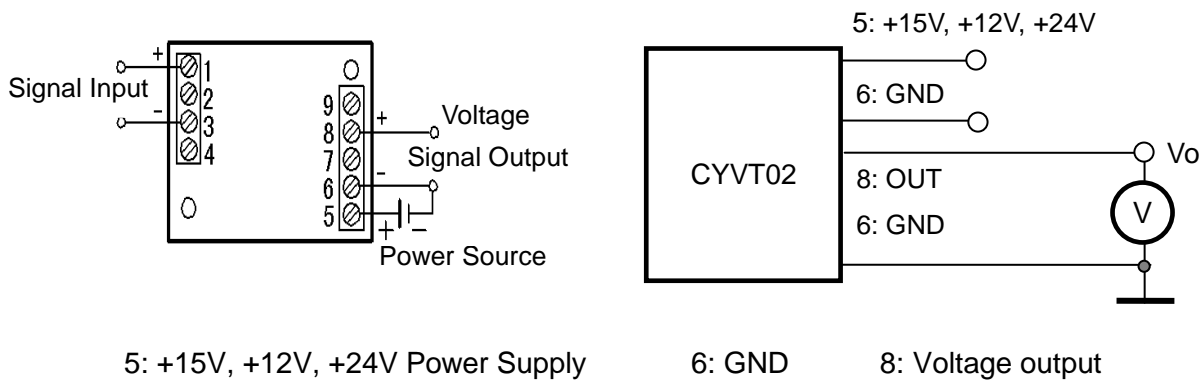

**Relation between Input and Output:**

Sensor CYVT02-32S2-0.5-U1000V		Sensor CYVT02-32S2-0.5-B1000V	
Input voltage (V)	Output voltage (V)	Input voltage (V)	Output voltage (V)
0	0	-1000	0
250	1.25	-500	1.25
500	2.5	0	2.5
750	3.75	500	3.75
1000	5	1000	5

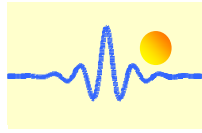

### Wiring of Terminals for Current Output:

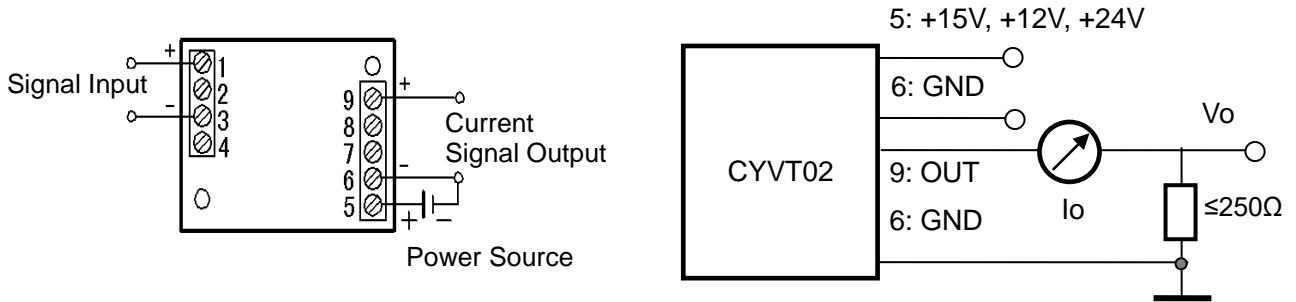

5: +15V, +12V, +24V Power Supply      6: GND      9: Current output

Relation between Input and Output (for  $R_m=250\ \Omega$ ):

Sensor CYVT02-54S2-0.5-U1000V			Sensor CYVT02-54S2-0.5-B1000V		
Input voltage (V)	Output current $I_o$ (mA)	Output voltage $V_o$ (V)	Input voltage (V)	Output current $I_o$ (mA)	Output voltage $V_o$ (V)
0	4	1	-1000	4	1
250	8	2	-500	8	2
500	12	3	0	12	3
750	16	4	500	16	4
1000	20	5	1000	20	5

### Wiring of Terminals for OC Frequency Output:

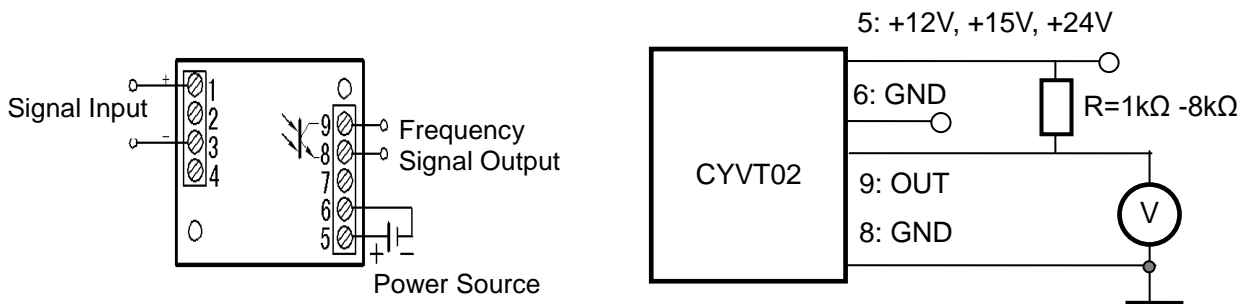

The value of the pull-up resistor R should be selected in order to get a current of 4-5mA flowing through the pull-up resistor. For instance the pull-up resistor is  $24V/4.5mA=5.3k\Omega$  if you use a power supply +24VDC.

Recommended value of the pull-up resistor R

Power supply	+12V	+15V	+24V
Pull-up resistor R	2.6k $\Omega$	3.3k $\Omega$	5.3k $\Omega$