

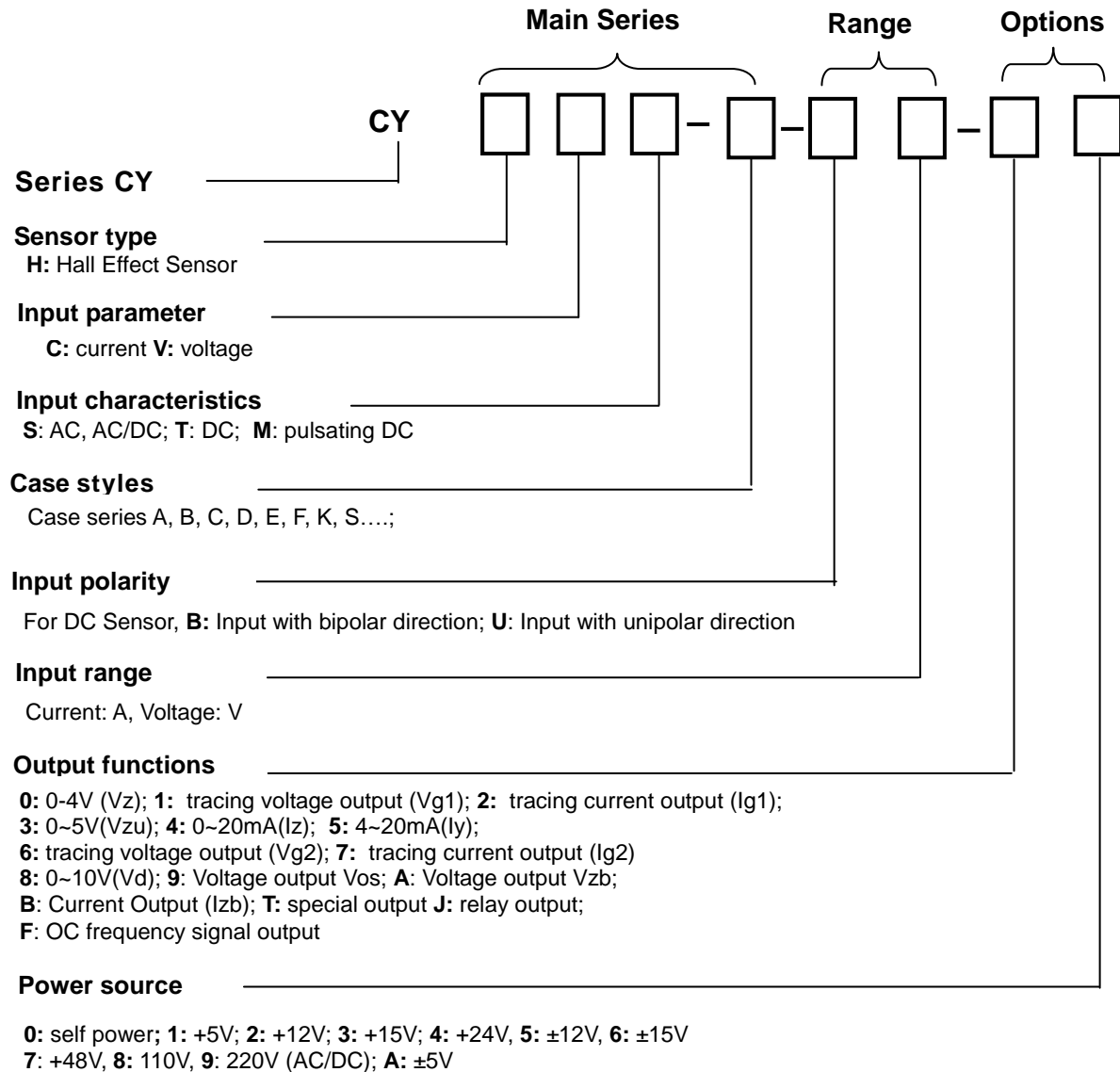

Product Overview of Hall Effect Sensors/Transducers

Part Number



Typical Examples:

CYHCT-S3-U100A-32: Hall Effect DC Current Transducer, Output: 0-5VDC, Power Source: +12VDC, Case Style: S3 with Window Φ20mm, Input Range: 0-100ADC.

CYHCT-S3-B100A-32: Hall Effect DC Current Transducer, Output: 0-5VDC, Power Source: +12VDC, Case Style: S3 with Window Φ20mm, Input Range: -100A ~ +100A DC.

CYHCS-E4-100A-35: Hall Effect AC Current Transducer, Output: 0-5VDC, Power Source: ±12VDC, Case Style: E4 with Window Φ21mm, Input Range: 100A AC.

CYHCS-E4-100A-15: Hall Effect AC/DC Current Transducer, tracing Output: 5V, Power Source: ±12VDC, Case Style: E4 with Window Φ21mm, Input Range: -100A ~ +100A AC/DC.

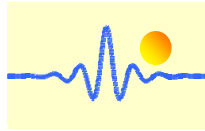

Output Function Codes

Code	Symbol	Definition	Applications
0	Vz	DC Voltage Output	0-4V DC, can be connected direct to A/D converter, digit panel, indicator, PLC
1	Vg1	Tracing Voltage Output	5V (V_{p-p}), suitable for AC/DC or peak value sampling system, quick response, high precision.
2	Ig1	Tracing Current Output	20mA (I_{p-p}), suitable for AC/DC sampling and peak value sampling system, high precision, and quick response.
3	Vzu	DC Voltage Output	0-5V DC, can be connected direct to A/D converter, digit panel, indicator, PLC
4	Izu	DC Current Output	0-20mA DC, suitable for long distance signal transmission, resistance to interference.
5	Iy	DC Current Output	4-20mA DC, suitable for long distance signal transmission, resistance to interference.
6	Vg2	Tracing Voltage Output	4V (V_{p-p}), suitable for AC/DC or peak value sampling system, quick response, high precision
7	Ig2	Tracing Current Output	20mA ~ 200mA (I_{p-p}), suitable for AC/DC sampling and peak value sampling system, high precision, and quick response.
8	Vd	DC Voltage Output	0-10 V DC, can be connected direct to digit panel, indicator etc. (power source $\geq 15V$).
9	Vos	Tracing Voltage Output with Offset	+2.5VDC +/-1.0V or +2.5VDC +/-0.625V, suitable for single power supply systems
A	Vzb	DC Voltage Output	-5V ~ +5VDC, can be connected direct to A/D converter, digit panel, indicator, PLC
B	Izb	DC Current Output	-20mA ~ +20mADC, suitable for long distance signal transmission, resistance to interference.
F	F	OC frequency signal output	0~10 kHz frequency signal or custom frequency signal, photoelectric isolation OC output
J	J	Relay touch point	Use to inspect and offside alarm for AC/DC current and voltage
T	T	Special Output	Reserved for special output configurations.

Input / Output Graphs.

a) Tracing Voltage Output (Vg1, Vg2) or Tracing Current Output (Ig1, Ig2)

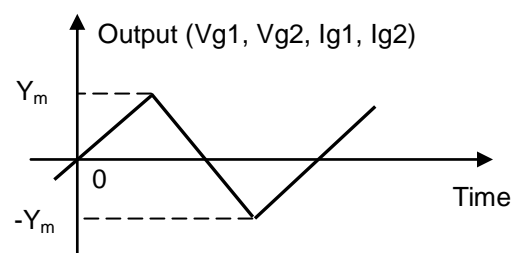
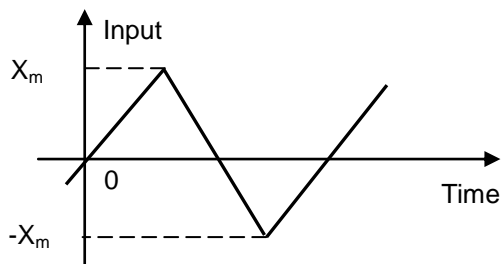

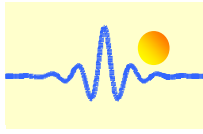

b) DC Voltage Output V_{zu} , V_d and V_{zb}

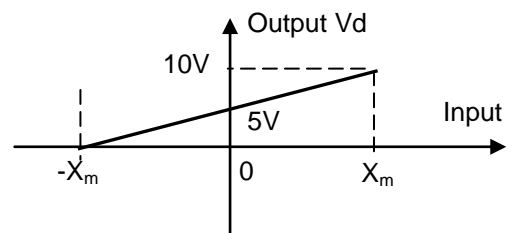
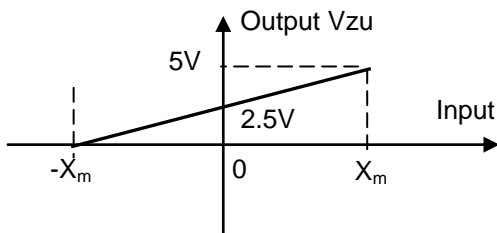
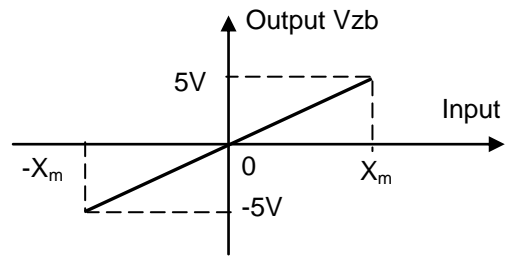
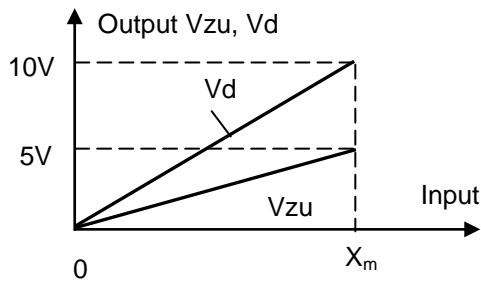

c) DC Current Output I_{zu} and I_{zb}

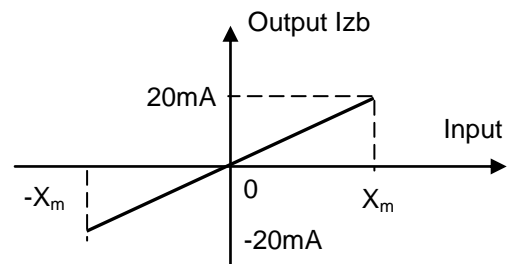
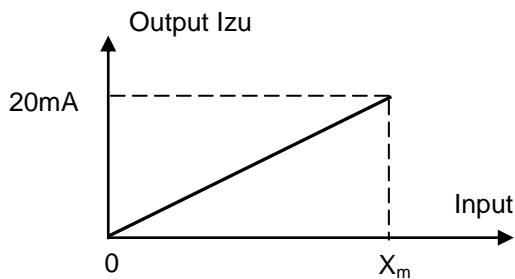

d) DC Current Output I_y

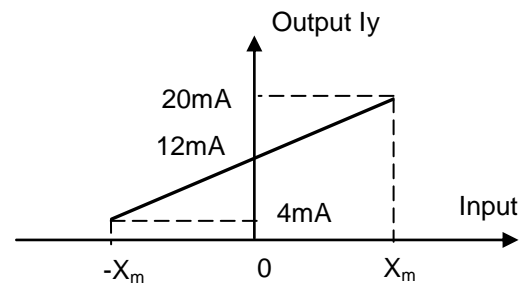
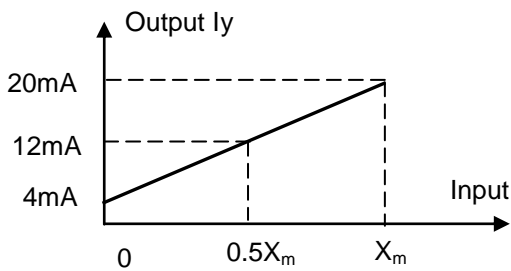

e) Tracing Voltage Output V_{os}

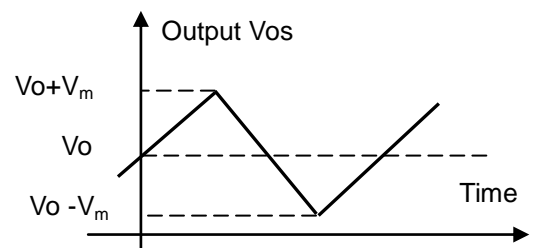
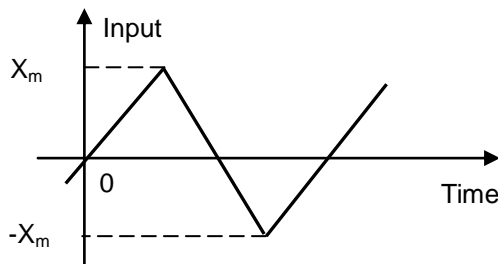

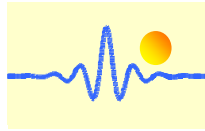

Output Signal Limitations of Sensors with Single Power Supply

Internal DC/DC Converting of Single Power Supply:

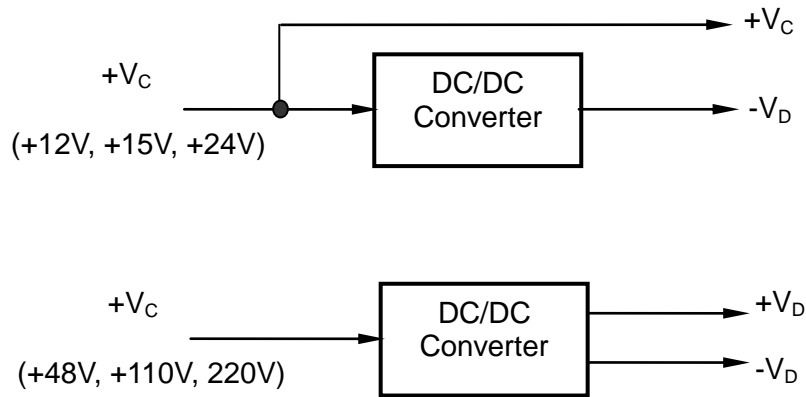

Power supply V_C	Power supply V_D	Output Signal
+12VDC	-6VDC	Not 0-10VDC and -10V~+10VDC, all other output signals are available
+15VDC	-6VDC	Not -10V ~ +10VDC, all other output signals are available
+24VDC	-15VDC	All output signals are available
$\pm 12VDC$	x	Not -10V ~ +10VDC, all other output signals are available
$\pm 15VDC$	x	All output signals are available
+48VDC	$\pm 15VDC$ or $\pm 24VDC$	All output signals are available
+110VDC	$\pm 15VDC$ or $\pm 24VDC$	All output signals are available
220V DC/AC	$\pm 15VDC$ or $\pm 24VDC$	All output signals are available